

WHAT IS AT STAKE

For obvious safety reasons, a vehicle is not allowed to drive with defective lighting. However, the rear lights are exposed and could break if hit during manoeuvring. They should therefore be well protected.

THE CHEREAU SOLUTION

CHEREAU has developed Flex-C LED, a virtually unbreakable light system. Equipped with an ultra-strong polycarbonate shell, the light is mounted on a patented flexible support that retracts towards the front of the trailer in the event of an impact. It then returns automatically into place. The LED technology guarantees reliability and a long service life.

- Glowing" type lighting
- Scrolling indicators
- Flex-C media compatible
- Built-in fault detection (TMU)
- Tightness IP69K
- Integrated horn lights
- 5 year warranty



Position

Fog lamps

Stop



Flashing lights

Hindsight

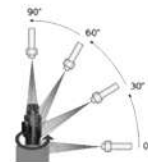

Connection
TL DIN



The Flex-C LED system connections are protected by a stainless steel fairing which makes them watertight and reliable.

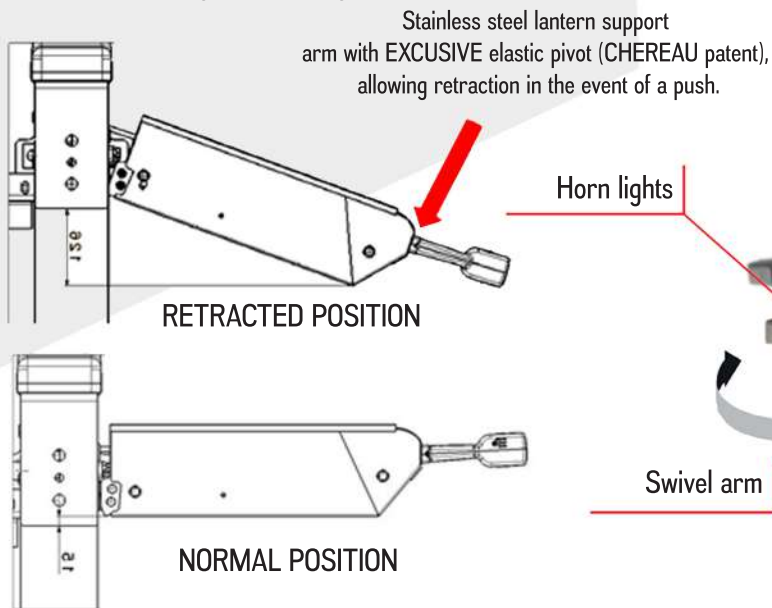

Signalling lantern grouping the functions: position, direction, stop (permanently controlled by an electronic box on board the tractor), reverse, fog, retro-reflector triangle.