



Maintenance instructions

BPW Trailer Axles and Suspensions



Contents

◎ 1.	Important information	Page 3
1.1	General	Page 3
1.2	Maintenance, repair and spare parts	Page 3
1.3	Definition On-Road / Off-Road	Page 3
1.4	Latest version	Page 3
◎ 2.	Safety instructions	Page 4
◎ 3.	BPW Trailer axles / BPW Steering axles	Page 6
3.1	Lubrication	Page 6
3.2	Maintenance Work and Visual Inspection	
3.2.1	General	Page 23
3.2.3	Drum brakes	Page 24
3.2.3	Disc brakes, brake types TSB 3709, TSB 4309, TSB 4312	Page 40
3.2.4	Disc brakes, brake types SB 3308, SB 3745, SB 4309, SB 4345	Page 50
◎ 4.	BPW Air suspension, series EAC (ECO Air COMPACT)	Page 64
4.1	Overview, Maintenance Work and Visual Inspection	Page 64
4.2	Maintenance Work and Visual Inspection	Page 66
◎ 5.	BPW Air suspension, series O, SL, AL	Page 72
5.1	Overview, Lubrication and Maintenance Work, Visual Inspection	Page 72
5.2	Lubrication	Page 76
5.3	Maintenance Work and Visual Inspection	Page 76
◎ 6.	BPW Mechanical suspensions (leaf springs), series ECO Cargo VB / VB HD	Page 86
6.1	Overview, Lubrication and Maintenance Work, Visual Inspection	Page 86
6.2	Lubrication	Page 88
6.3	Maintenance Work and Visual Inspection	Page 89
◎ 7.	BPW Mechanical suspensions (leaf springs), series ECO Cargo W / BW / GW	Page 92
7.1	Overview, Lubrication and Maintenance Work, Visual Inspection	Page 92
7.2	Lubrication	Page 94
7.3	Maintenance Work and Visual Inspection	Page 95

Important information 1

1.1. General

The following maintenance instructions apply to BPW trailer axles and BPW suspensions for drawbar trailers and semi-trailers (manufactured from 1982 onwards). They are part of the Terms and Conditions for the ECO Plus Warranty (see warranty documents at www.bpw.de).

Carry out the latest maintenance instructions in accordance with the prescribed intervals in order to maintain the safe operation and roadworthiness of the vehicle. The latest version of the maintenance instructions can always be found at www.bpw.de. The latest printed version is available by post on request. The relevant operation and service regulations of the vehicle manufacturer and the manufacturers of other vehicle parts must also be adhered to.

These maintenance intervals are set out in calendar weeks and are listed to coincide with statutory testing requirements (ZU, HU, BSU).

1.2. Maintenance, Repair and Spare Parts

Rectification of any discovered defects or replacement of worn parts should be carried out by a BPW Service Centre or BPW Direct Service Partner unless the vehicle owner has the appropriate trained personnel, facilities, equipment and workshop manuals available and possesses an official certificate to perform interim inspections or special brake inspections.

We strongly recommend that only genuine BPW parts, brake linings in particular, are used when fitting spare parts. Parts authorised by BPW for trailer axles and axle units are regularly subjected to special inspections. BPW accepts product responsibility for them.

BPW is unable to determine whether all third party products can be used with BPW trailer axles and axle suspensions without any safety risk; this also applies even if an authorised testing organisation has accepted the product.

The ECO Plus Warranty (see warranty documents) will cease to apply if spare parts other than genuine BPW spare parts are used.

1.3. Definition On-Road / Off-Road

The term „On-Road“ refers to roads having a sealed and metalled surface, in other words with an asphalt or concrete surface. Gravel roads are regarded as being Off-Road. A vehicle is also regarded as being in Off-Road operation even if it departs from sealed surfaces under operating conditions for only short periods. Off-Road operation is assumed in all cases in tippers and vehicles with comparable applications.

1.4. Latest Version

The latest maintenance instructions are dated 01.06.2016 and replace maintenance instructions BPW-W 33111501e. All previous maintenance instructions become invalid. We reserve the right to make any changes.

2 Safety instructions

The following instructions should also be adhered to by the driver in addition to the statutory regulations:

In case of a new vehicle:

- After the first run under load conditions and after each wheel change:
 - Check wheel nuts for firm seating using a torque wrench. See point [1](#) on page 26, 42, 52.
- After the first two weeks (after the first runs under load conditions):
 - Check that the bolt connections of the spring attachments and axle steering devices are secure, depending on the application (On-Road or Off-Road). Observe the stipulated tightening torques.
 - Air suspensions: see [4](#) to [9](#) page 78 - 82
 - Leaf-spring suspensions: see [2](#) and [4](#) page 89 - 90
see [1](#) and [3](#) page 95

Prior to each run:

- Air reservoir of the brake and air suspension set at operating pressure.
- Visual inspection:
 - Tyre pressure
 - Wheel fixings
 - Check operation of lighting and braking systems
 - Drum brake: Check the brake pad/lining thickness when the brake pad/lining wear indicator is in the horizontal position.
 - Disc brake: Check the remaining brake pad / lining thickness.
Type TSB: The thickness of the remaining pad can be determined by the position of the caliper in relation to the brake carrier (see page 43).
Type SB: The thickness of the remaining pad can be detected by the position of the brake caliper in relation to the stationary guide sleeve (see pages 53 - 54).
 - Check that the air suspension has reached ride height and the air bags are not creased. This also applies after rapid loading or unloading.
 - Normal ride level of the air bags, check air bags are not creased. This also applies to rapid loading or unloading.

In the event of daily frost or in accordance with manufacturer's instructions:

- Drain off condensation water via the drainage valve at the bottom of the air reservoirs.
- Check the valve system.

Quarterly:

- Clean line filter (in accordance with manufacturer's instructions).

Proper use of the braking system:

- In the event of premature wear of the brake pads, a tractor/trailer harmonisation (according to ISO 20918 is to be carried out.
- To maintain the efficiency of the braking system, regular use of the wheel brakes with the appropriate level of heat generation is recommended.
- Before proceeding with an HU or SP (PTI), the braking system performance where applicable, must be measured (see ISO 7634).
- The appropriate installation and operating instructions for BPW brake components (see www.bpw.de) should be observed.

We wish you a safe journey!

3 BPW Trailer axles / BPW Steering axles

3.1 Lubrication

Overview	Every 6 weeks	Every 12 weeks	Every 26 weeks ^{1) 2)}	At every brake lining replacement ²⁾	Latest annually ¹⁾	Latest every 2 years	Annually	Every 2 years	Latest every 3 years or min. every 500,000 km ²⁾	Every 3 years	After 5 years, thereafter every 3 years
For detailed description see pages 8 - 21											
① Steering pivot bearing, top and bottom	①										
② Brake camshaft bearing, outer and inner On-Road conditions Off-Road conditions Outside Europe			② ②		②						
③ Slack adjusters manual Slack adjuster ECO-Master: On-Road conditions Off-Road conditions Outside Europe		③			③						
④ Brake shoes with closed anchor eye						④					
⑤ ECO Plus 3, ECO Plus 2 and ECO ^{plus} Unit: On-Road conditions Off-Road conditions Outside Europe: On-Road conditions Outside Europe: Off-Road conditions ECO Unit Outside Europe Conventional hub bearing								⑤		⑤	⑤

For positions ① to ③ the use of a high-pressure central lubrication system which is capable of feeding special longlife grease of consistency class 2-3 is permissible. The use of liquid lubricants is not permitted!

¹⁾ After a long idle period, prior to initial operation actuate the brake lever and lubricate the brake camshaft bearing.

²⁾ With use under extreme conditions (e.g. extreme Off-Road use) more frequent lubrication with high pressure grease is necessary.

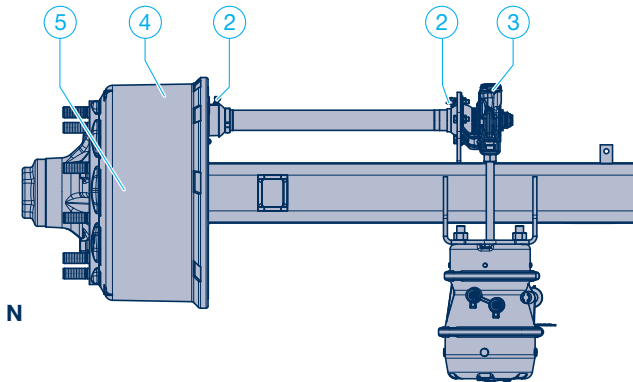

Series H / K / N

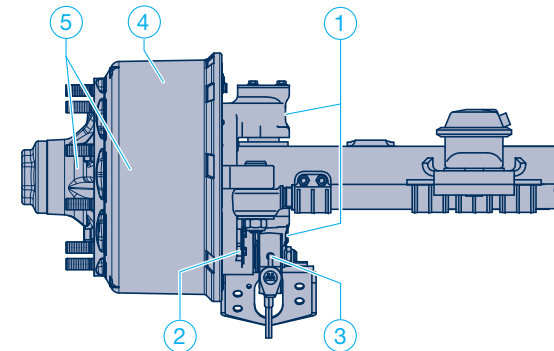

Series ...LL

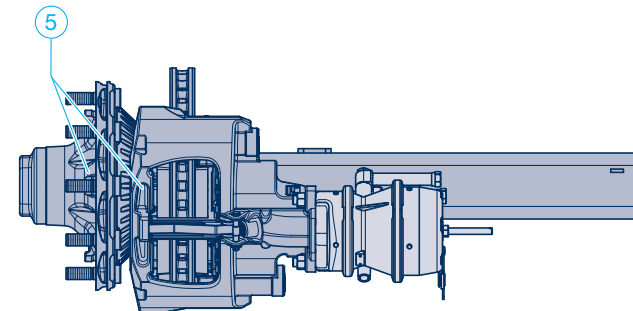

Series SH / SKH

3 BPW Trailer axles / BPW Steering axles

3.1 Lubrication

Note: After cleaning the vehicle with high-pressure cleaners, all lubrication points must be relubricated.

① Steering pivot bearing, top and bottom – every 6 weeks –

Lift axle in order to relieve the steering pivot bearing. Grease lubrication nipple with BPW special longlife grease **ECO-Li^{Plus}** until fresh grease emerges from the bearing points.

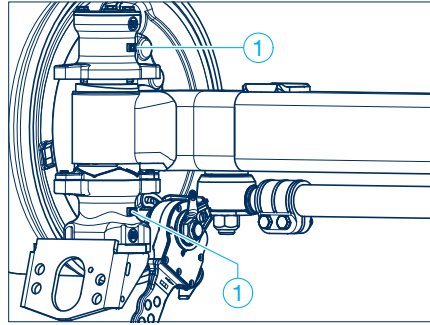

② Brake camshaft bearing, outer and inner

Low maintenance brake camshaft bearing (from year of manufacture 1993)

- every year and with each brake lining change in On-Road use –
- every 6 months in Off-Road use and in use outside Europe –

Prevent the vehicle from rolling away.
Release the service brakes and the handbrake.

Lubricate the brake camshaft bearing through the grease nipple with BPW special longlife grease **ECO-Li^{Plus}** until fresh grease emerges from the bearing points.

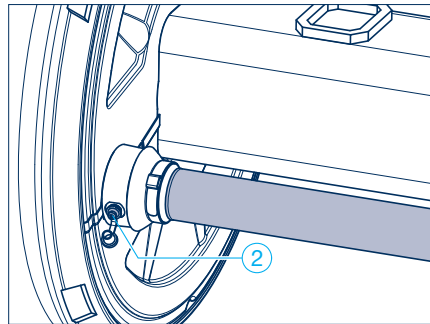

 **Important!**
Use of other grease is not permitted!

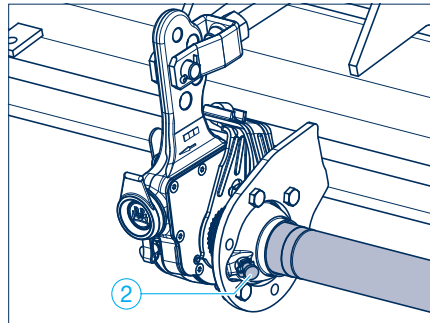

③ Slack adjusters (manual) – quarterly –

Grease lubrication nipple with BPW special longlife grease **ECO-Li^{Plus}** until fresh grease emerges.

Automatic slack adjuster ECO-Master – every year and with each brake lining change in On-Road use – – every 6 months in Off-Road use and in use outside Europe –

Remove rubber seal cap. Grease with BPW special longlife grease **ECO-Li^{Plus}** (approx. 80 g) until sufficient new grease emerges from the adjustment bolt.

Turn back adjustment screw (keep clutch sleeve pressed down) by approx. one turn using a ring spanner. Actuate the brake lever several times by hand. The adjustment must be carried out smoothly. If necessary, repeat several times.

Once again only use BPW special longlife grease **ECO-Li^{Plus}**.
Install seal cap.

Adjust the brake - see relevant workshop manual.

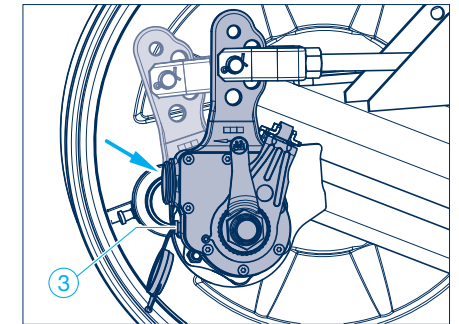
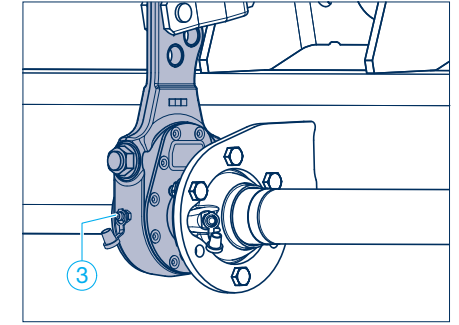

④ Brake shoes with closed anchor eye – every 2 years and with each brake lining change –

Clean the bush and roller, check for wear and, if necessary replace. Smear BPW special longlife grease **ECO-Li^{Plus}** onto bearing points of brake shoe.

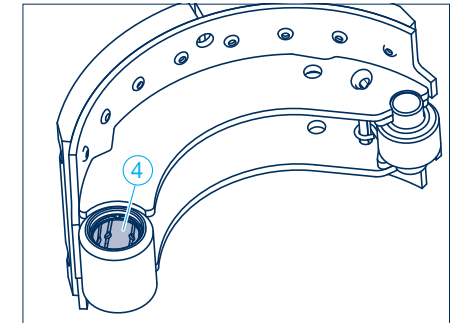

3 BPW Trailer axles / BPW Steering axles

3.1 Lubrication

5 ECO Plus 3 Unit

– for the first time after 5 years in On-Road use, or every 3 years in Off-Road use in Europe, then at least every 3 years depending on operating conditions –

– every 2 years in On-Road use or every year in Off-Road use outside Europe –

Prevent the vehicle from rolling away.
Remove the wheel.

Unscrew the cap with a 110 mm cap spanner.

Dismantle the ECO Unit - see the corresponding workshop manuals.

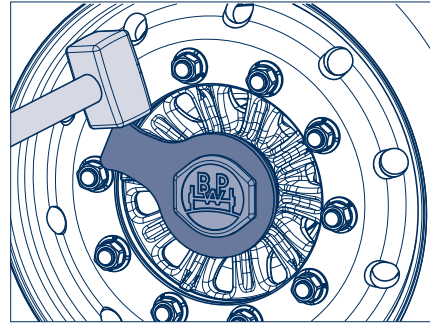

Mark both the hub and bearing to ensure correct positioning during re-assembly. It is essential for the bearing inner rings with rollers to be re-inserted in the same hubs.

Thoroughly clean taper roller bearings and seals (using e.g. diesel oil), dry and check for re-useability. Replace grease seal.

(Recommendation: Renew the tapered roller bearings after 5 years in On-Road and after 3 years in Off-Road use.)

Work BPW special longlife grease **ECO-Li^{Plus}** thoroughly into the cavities between the taper rollers and the cage in both taper roller bearings. (For grease quantity see illustration on page 11.) Smear any residual grease into the hub's outer bearing race.

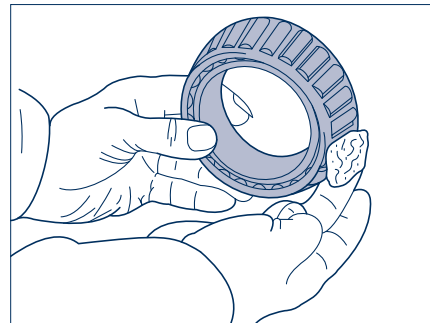

Smear the lip of the new seal all round with BPW special longlife grease **ECO-Li^{Plus}**.

Clean the bearing seats of the axle stub (metal must be bright, dry and free from grease). Spray with **BPW ECO Assembly and Protection Spray**. Allow to dry for about 10 minutes until the film changes to a marked matt colour.

Install ECO unit whilst continuously rotating axle nut of ECO unit. It should take several turns until the clutch on the axle nut slips.



Important!
Do not use an impact driver.

Fit the retaining key in the groove between the stub axle and the nut (do not reset the axle nut).

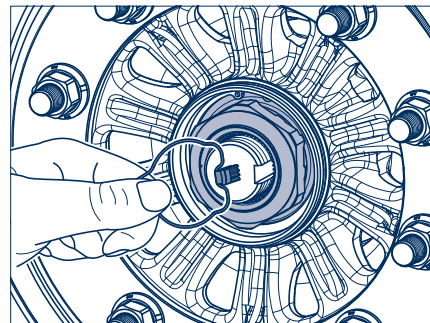

Insert the hooked retainer spring behind the formed edge of the axle nut.

Insert a new O-ring into the annular groove of the wheel hub. Apply a thin coat of BPW special longlife grease **ECO-Li^{Plus}** to the O-ring contact surface and thread of the hub cap.

Screw on the hub cap and tighten to **350 Nm**.

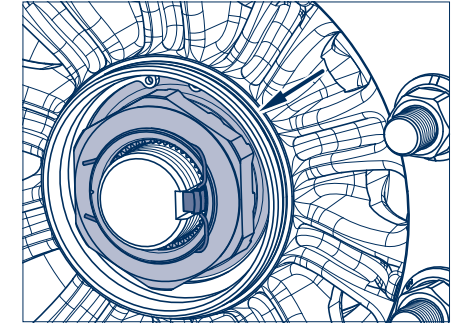

ECO Plus 3 Unit

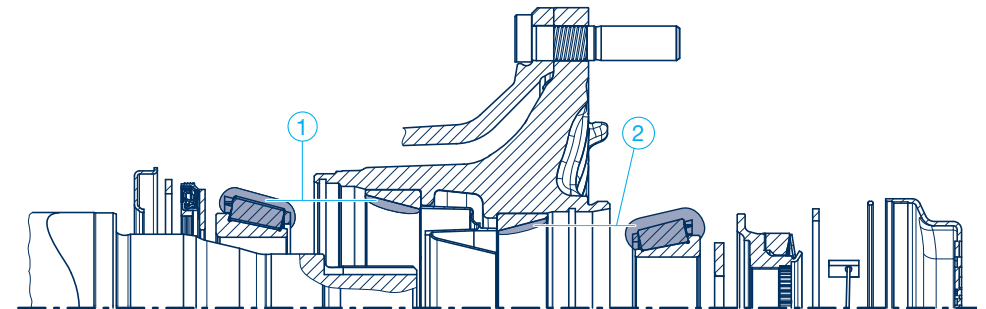

	BPW special longlife grease ECO-Li ^{Plus} Grease quantity per taper roller bearing	
	① Inner bearing	② Outer bearing
Manual greasing	170 g	120 g
Greasing with a grease applicator	130 g	90 g

3 BPW Trailer axles / BPW Steering axles

3.1 Lubrication

ECO Plus 2 Unit

– for the first time after 5 years in On-Road use, or every 3 years in Off-Road use in Europe, then at least every 3 years depending on operating conditions –

– every 2 years in On-Road use or every year in Off-Road use outside Europe –

Prevent the vehicle from rolling away.
Remove the wheel.

Unscrew the cap with a 120 mm cap spanner.

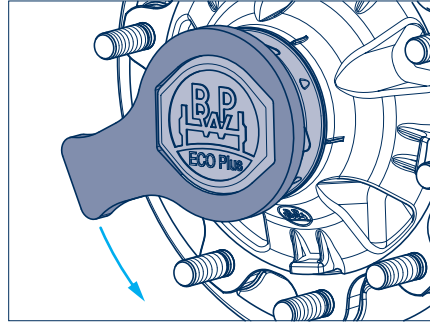

Important!
Do not use an impact driver - bayonet lock.

Undo the cap by turning it anti-clockwise by approx. 30° from position 1 to position 2.

When turned further the hub cap lifts clearly away from the ECO Unit and can be removed by pulling it away.

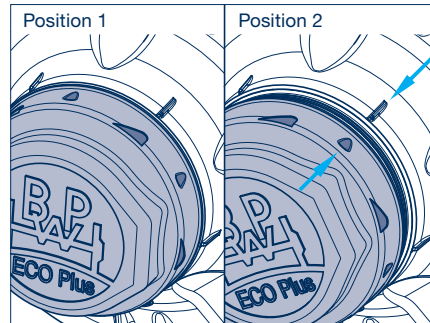

Remove the hooked spring ring and retaining key from the axle bolt.

Unscrew the axle bolt, pulling the complete ECO Unit off the bearing seats of the axle stub as you do so.

Dismantle the ECO Unit - see the corresponding workshop manuals.

 Mark both the hub and bearing to ensure correct positioning during re-assembly. It is essential for the bearing inner rings with rollers to be re-inserted in the same hubs.

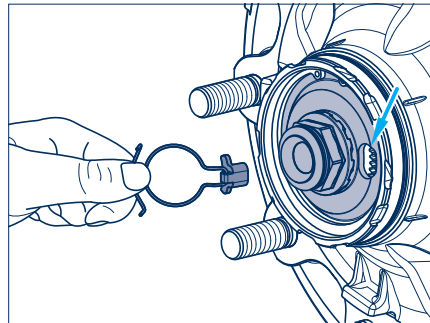



Clean the tapered roller bearings thoroughly (e.g. with diesel oil), dry them and check if they can be re-used. Fit a new shaft seal.

(Recommendation: Renew the tapered roller bearings after 5 years in On-Road use and after 3 years in Off-Road use.)

Clean the grease cartridge and fill it on both sides up to the edge with BPW special longlife grease **ECO-Li^{Plus}**. It is important to ensure that it is filled without any trapped air or cavities.

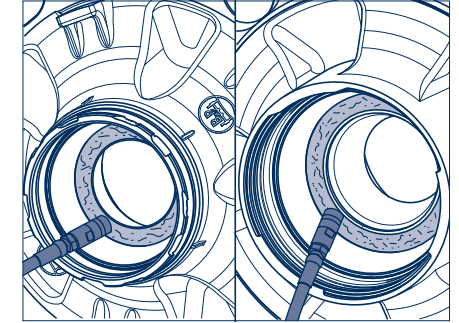
Apply a ring-shaped bead of grease to the running surfaces of the bearing outer races (see arrows in illustration below).



 When BPW grease applicators are used, there is no need to fill the grease cartridge or to apply the bead of grease.

Mount the ECO Unit.

Clean the bearing seats of the axle stub (metal must be bright, dry and free from grease). Spray with **BPW ECO Assembly and Protection Spray**. Allow to dry for about 10 minutes until the film changes to a marked matt colour.

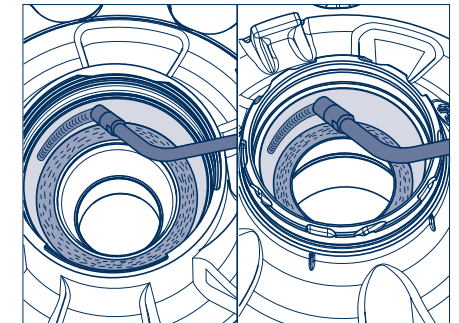

	BPW special longlife grease ECO-Li ^{Plus}	
	Grease quantity per taper roller bearing	
	① Inner bearing	② Outer bearing
Manual greasing	170 g	120 g
Greasing with a grease applicator	130 g	90 g

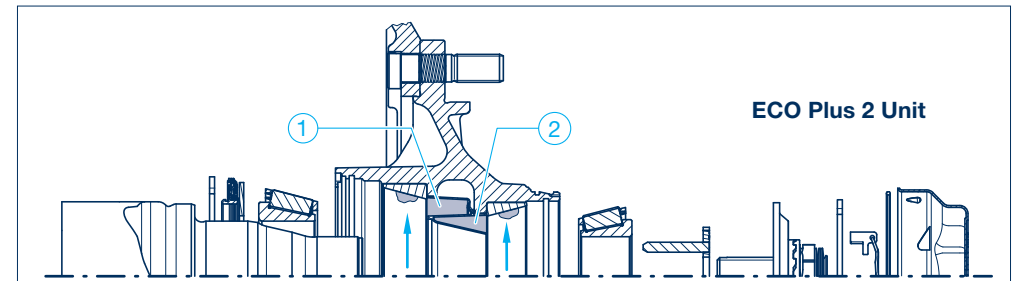

3 BPW Trailer axles / BPW Steering axles

3.1 Lubrication

Apply only a **thin** layer of BPW ECO-Li^{Plus} to the threaded hole in the axle stub.

 **Important!**
Do not apply too much grease!

It is necessary to make sure that the axle bolt can be completely screwed into the axle stub.

Mount the ECO Unit. Guide the toothed lock washer into the hole in the axle stub. The position of the pin can be seen by the punched-in BPW logo in the recess of the axle bolt.

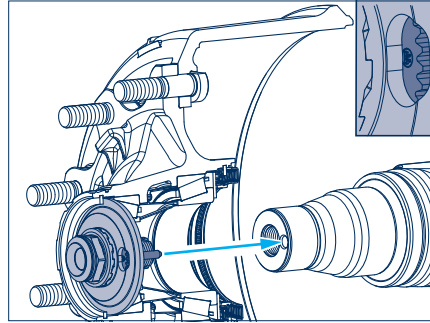

Fasten axle bolt (SW 46) whilst rotating the ECO hub unit. It should take several turns until the clutch on the axle bolt slips. (Do not turn back the axle bolt).

 **Important!**
Do not use an impact driver.

Insert the retaining key into the recess in the axle bolt and the gearing of the toothed lock washer. (Do not turn back the axle bolt.)

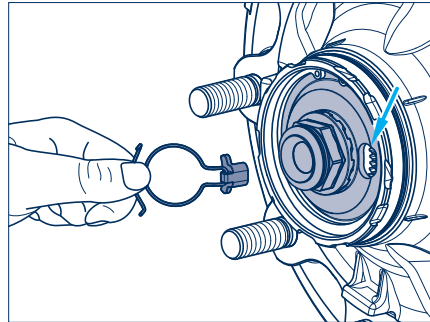

Insert the hooked spring ring into the groove of the hexagon profile of the axle bolt.

 **Make sure that the hooked spring ring assembly is correctly seated in the annular groove of the axle bolt.**

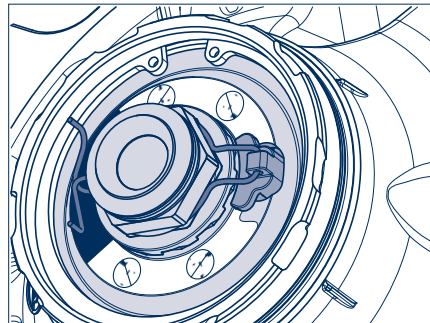

Insert a new O-ring into the groove in the wheel hub.

Apply a thin layer of BPW ECO-Li^{Plus} special longlife grease to the cap in the area of the O-ring contact surface and the bayonet fitting.

Screw on the cap with a 120 mm cap spanner.



Important!
Do not use an impact driver - bayonet lock.

Push on the cap, see position 1.
Press on the cap and turn it by approx. 30° in a clockwise direction to lock it in place. A tight seat is provided when position 2 is reached.

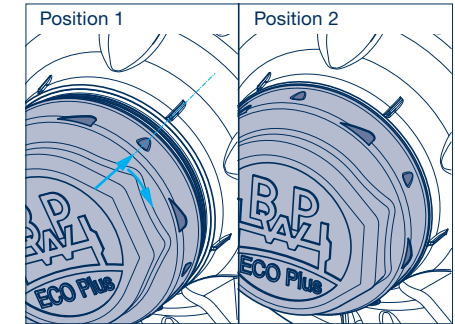

3 BPW Trailer axles / BPW Steering axles

3.1 Lubrication

ECO^{Plus} Unit

– for the first time after 5 years in On-Road use, or every 3 years in Off-Road use in Europe, then at least every 3 years depending on operating conditions –

– every 2 years in On-Road use or every year in Off-Road use outside Europe –

Prevent the vehicle from rolling away.
Remove the wheel.

Unscrew the cap with a 110 mm cap spanner.

Dismantle the ECO Unit - see the corresponding workshop manuals.

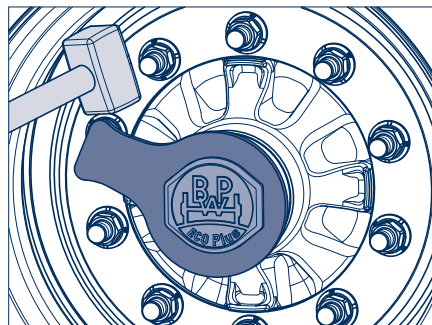

Mark both the hub and bearing to ensure correct positioning during re-assembly.

It is essential for the bearing inner rings with rollers to be re-inserted in the same hubs.

Thoroughly clean taper roller bearings and seals (using e.g. diesel oil), dry and check for re-useability. Replace grease seal.

(Recommendation: Renew the tapered roller bearings after 5 years in On-Road and after 3 years in Off-Road use.)

Work BPW special longlife grease **ECO-Li^{Plus}** thoroughly into the cavities between the taper rollers and the cage in both taper roller bearings. (For grease quantity see illustration on page 17.) Smear any residual grease into the hub's outer bearing race.

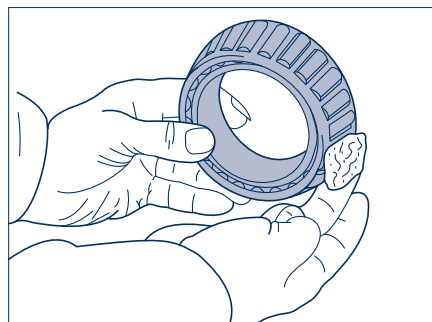

Smear the lip of the new seal all round with BPW special longlife grease **ECO-Li^{Plus}**.

Clean the bearing seats of the axle stub (metal must be bright, dry and free from grease). Spray with **BPW ECO Assembly and Protection Spray**. Allow to dry for about 10 minutes until the film changes to a marked matt colour.

Install ECO unit whilst continuously rotating axle nut of ECO unit. It should take several turns until the clutch on the axle nut slips.



Important!
Do not use an impact driver.

Fit the retaining key in the groove between the axle stub and the nut (do not reset the axle nut).

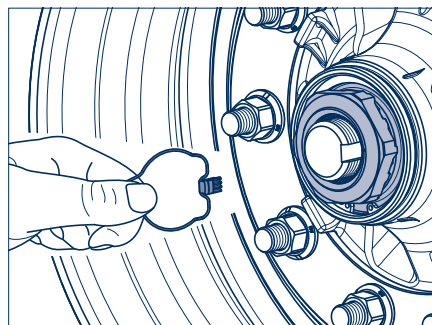

For production date April 2000 onwards, insert the hooked spring ring behind the edge of the axle nut or, up to March 2000, into the thread on the axle stub. Screw on the cap and tighten to 800 Nm.

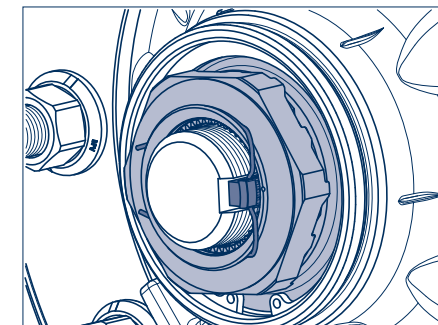

ECO^{Plus} Unit

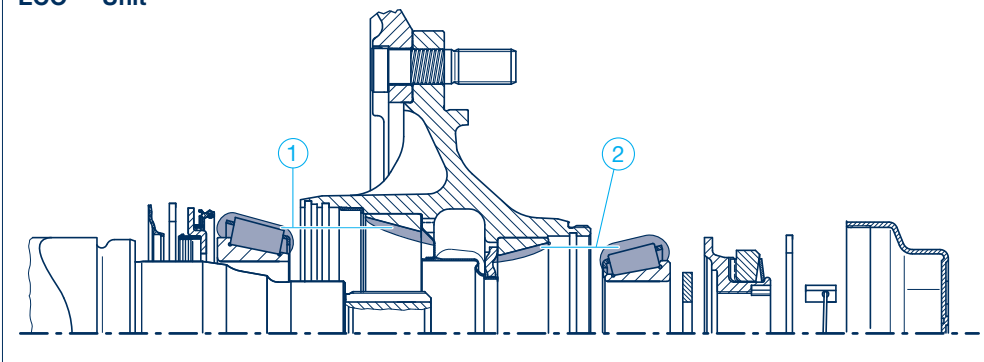

	BPW special longlife grease ECO-Li ^{Plus} Grease quantity per taper roller bearing	
	① Inner bearing	② Outer bearing
Manual greasing	170 g	120 g
Greasing with a grease applicator	130 g	90 g

3 BPW Trailer axles / BPW Steering axles

3.1 Lubrication

ECO Unit

– latest every 3 years or min. every 500,000 km (Western European road conditions), annually in use outside Europe –

Prevent the vehicle from rolling away. Remove the wheel.

Unscrew the cap with a 110 mm cap spanner.

Dismantle the ECO Unit - see the corresponding workshop manuals.

 **Mark both the hub and bearing to ensure correct positioning during re-assembly. It is essential for the bearing inner rings with rollers to be re-inserted in the same hubs.**

Thoroughly clean taper roller bearings and seals (using e.g. diesel oil), dry and check for re-useability. Replace grease seal.

Work BPW special longlife grease **ECO-Li^{Plus}** thoroughly into the cavities between the taper rollers and the cage in both taper roller bearings.

Comply with the total grease quantity in tables **(A)** and **(B)**.

Smear any residual grease into the hub's outer bearing race. Smear the lip of the new grease seal all round with BPW special longlife grease **ECO-Li^{Plus}**.

Clean the bearing seats of the axle stub (metal must be bright, dry and free from grease). Spray with **BPW ECO Assembly and Protection Spray**. Allow to dry for about 10 minutes until the film changes to a marked matt colour.

Fit the ECO Unit.

Fasten axle nut using a torque wrench whilst rotating the ECO hub unit. It should take several turns until the tightening torque has reached 150 Nm. Turn the nut back until the next securing position is aligned. (max 15 degrees).

The next locking hole is reached by turning back the asymmetrical axle nut by a maximum of 15°. Fit pin with a snap hook. Tighten the cap to 800 Nm.

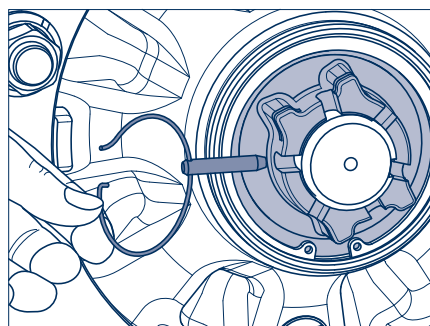
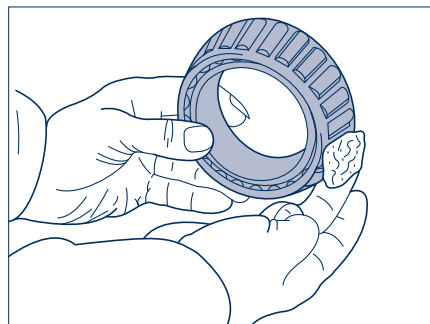

ECO Unit

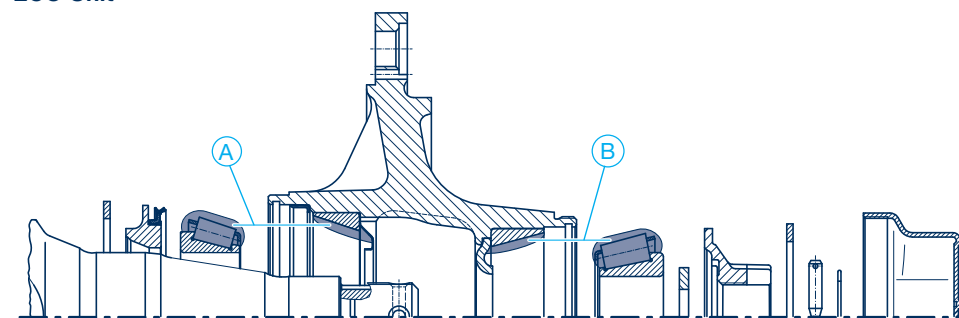

Axle load	BPW special longlife grease ECO-Li ^{Plus} Grease quantity per taper roller bearing	
	(A) Inner bearing	(B) Outer bearing
6000 - 9000 kg	120 g	120 g
10000 - 12000 kg	170 g	120 g
13000 - 14000 kg	230 g	150 g

3 BPW Trailer axles / BPW Steering axles

3.1 Lubrication

Change wheel hub bearing grease (Conventional)

– whenever brake linings are changed: at the latest annually or after 150,000 km –

For dismounting and re-fitting of wheel hubs, see workshop manuals.

 Mark both the hub and bearing to ensure correct positioning during re-assembly. It is essential for the bearing inner rings with rollers to be re-inserted in the same hubs.

Clean wheel hubs thoroughly inside and outside. Remove old grease completely.

Thoroughly clean taper bearings (using e. g. diesel oil) dry and check for re-useability. Replace seals.

Work BPW special longlife grease ECO-Li^{Plus} into the cavities between the taper rollers and cage.

Comply with total grease quantity (table **A**), smear any residual grease into the hub's outer bearing race.

Fit wheel hubs and adjust bearing play (see point **7** page 38).

Fill hub caps with BPW special longlife grease ECO-Li^{Plus} (table **B**) and screw on.

For tightening torques see **5** page 31.

 For 16 - 18 t axles with BPW oval shape hub cap, a new O-ring must be fitted on reassembly.

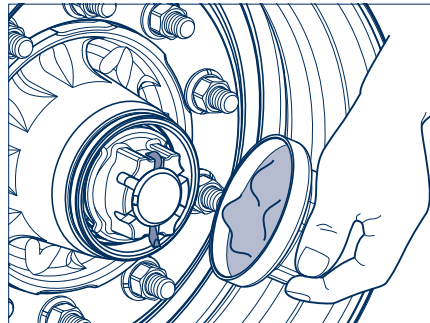
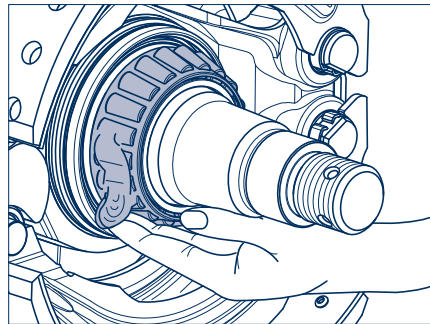
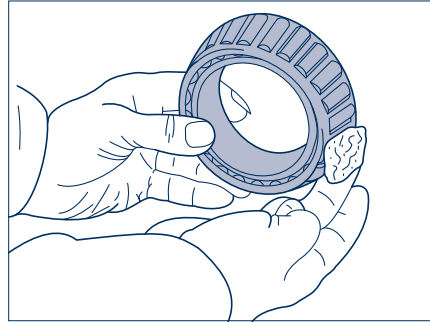

Conventional wheel hub bearing

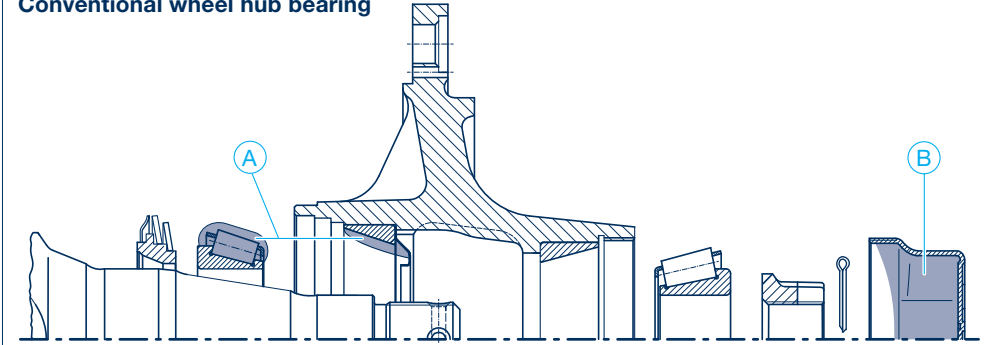

Axle load (Series H, K, N, M)	BPW special longlife grease ECO-Li ^{Plus} Grease quantity per taper roller bearing	
	A Inner bearing	B Outer bearing (cap filling)
4000 - 5500 kg	80 g	130 g
6000 - 9000 kg	170 g	290 g
10000 - 12000 kg	180 g	320 g
13000 - 14000 kg	240 g	500 g
16000 - 18000 kg	400 g	800 g
20000 kg	440 g	900 g
Axle load (Series E and NE)		
3000 kg	70 g	100 g
3500 - 3800 kg	80 g	120 g
4500 kg	90 g	180 g

BPW Trailer axles / BPW Steering axles **3**

Maintenance Work and Visual Inspection **3.2**

General **3.2.1**

In order to distribute the braking effort evenly to all the brakes in the unit, **adjustment must always be carried out according to the vehicle manufacturer's specifications, or after 5,000 km.** Tractor units with EBS cannot have their brakes adjusted in the normal manner. As a result, the trailer or semi-trailer merely has to be checked for compliance with the EC tolerance bands. Always check the tractor vehicle if the trailer is in the EC band despite premature brake pad wear. The EBS parameters in the tractor unit must be modified in order to improve compatibility, see ECE R 13 in this connection. Failure to do so will invalidate the warranty (see warranty documents).

Other possible solutions to premature brake pad wear:

- Prescribed maintenance work must be performed at regular intervals.
- Use the retarder or engine brake to adjust the vehicle's speed.
- Think ahead when driving.
- Drop down to a lower gear in good time.
- BPW Disc Protector (cover plates for brake discs).

Even at high temperatures, disc brakes display stable braking properties and a high level of safety. Excessive temperatures do not make themselves apparent through brake fading and should be avoided. This effect leads to increased wear when used under these conditions.

3 BPW Trailer axles / BPW Steering axles

3.2 Maintenance Work and Visual Inspection

3.2.2 Drum brakes

Overview	Initially	Every 1 to 3 weeks	Every 12 weeks	Every 26 weeks ²⁾	At every brake lining replacement, latest annually ²⁾
For detailed description, see pages 26 - 39 Disc brakes, see pages 40 - 62 Air suspension, see pages 64 - 84 Suspension, see pages 86 - 95					
Maintenance work - Drum brakes					
1 Check wheel nuts for tightness.	1 ¹⁾				
2 With manual slack adjusters, check brake play, adjust if necessary to 10 - 12% of the connected brake lever length and activate by hand or with 0.5 - 0.8 bar. (Not applicable in the case of automatic slack adjusters.)		2			
- Check the tyres for uneven wear, adjust the inflation pressure if necessary, according to the manufacturer's specifications.			-		
3 Check brake lining thickness is at least 5 mm. (Brake SN 300 min. 7 mm and N 3006 min. 2.5 mm residual lining thickness.)			3		
4 Check brake drum for cracks and check the internal diameter.			4		
5 Check caps for firm seating (not necessary with ECO Plus 3, ECO Plus 2 and ECO ^{Plus} axles).				5	
6 Check operation of automatic slack adjusters.			6 ³⁾	6	
o Visual inspection of all component parts and welding seams for damage and wear.			o ³⁾	o	
7 Check wheel hub bearing play, adjust if necessary. - ECO Plus 3, ECO Plus 2 and ECO ^{Plus} Unit - ECO Unit, conventional bearing				7	7

¹⁾ After the first run under load conditions, likewise after each wheel change.

²⁾ Under extreme conditions, increase frequency (e.g. construction sites and poor roads).

³⁾ For use outside Europe.

Note: Components that have damage due to improper mounting are to be exchanged after a review by a BPW Service Centre.

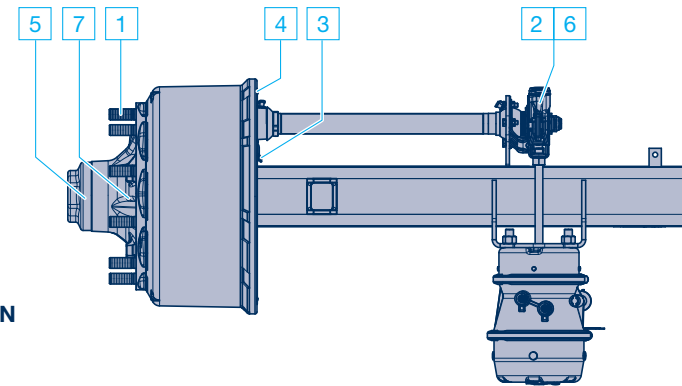

Series H / K / N

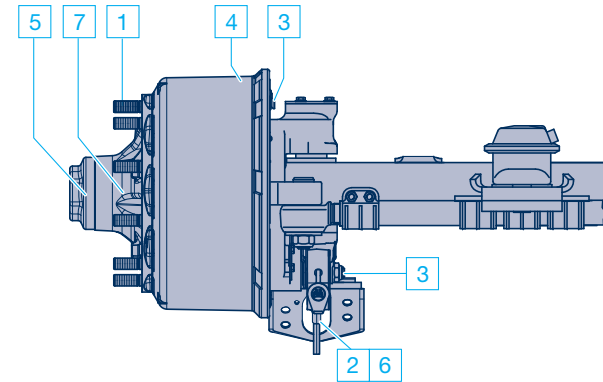

SeriesLL

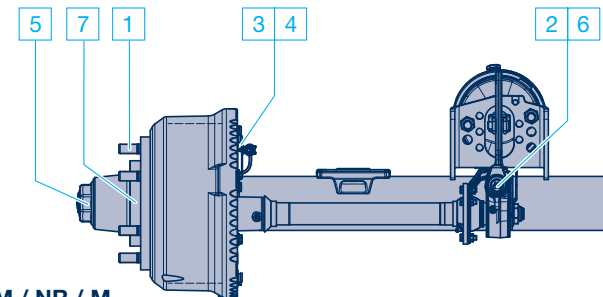

Series NE / NM / NR / M

3 BPW Trailer axles / BPW Steering axles

3.2 Maintenance Work and Visual Inspection

3.2.2 Drum brakes

1 Check wheel nuts for tightness

– the tightening torque of the wheel nuts must be checked after the first high load journey as well as after each wheel change and, if appropriate, retightened to the prescribed value –

Tighten wheel nuts diagonally using a torque wrench to the tightening torque shown in the table.

In the case of Trilex-wheels tighten the nuts consecutively several times around.

Wheel contact surfaces should not have additional coats of paint (risk of the wheels becoming detached!)

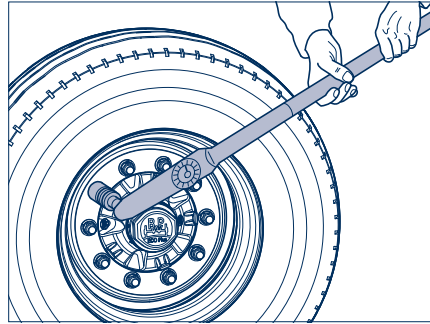

Tightening torque for wheel nuts



It is imperative that the prescribed tightening torques are adhered to in order to ensure the wheels are securely fastened! The wheel studs must be clean and free of damage and the nuts must be easily tightened and loosened. If needed, lightly oil the contact surface between the wheel nut and the pressure disc. Do not oil or grease the thread of the wheel studs and wheel nuts.



Stud alignment	Tightening torque	
M 14 x 1.5	125 Nm (120 - 130 Nm)	
M 18 x 1.5	290 Nm (275 - 305 Nm)	
M 20 x 1.5	380 Nm (360 - 400 Nm)	
M 22 x 1.5	510 Nm (485 - 535 Nm)	
M 22 x 2	460 Nm (435 - 485 Nm)	

Spigot alignment	Tightening torque	Wheel nut with collar
M 18 x 1.5	350 Nm (330 - 370 Nm)	
M 20 x 1.5	480 Nm (455 - 505 Nm)	
M 22 x 1.5	630 Nm (600 - 660 Nm)	
M 22 x 1.5 alloy wheels	630 Nm (600 - 660 Nm)	
M 24 x 1.5	860 Nm (820 - 900 Nm)	

Trilex-wheels	Tightening torque	
M 18 x 2	285 Nm (270 - 300 Nm)	
M 20 x 2	335 Nm (320 - 350 Nm)	

Japan connection	Tightening torque	
M 20 x 1.5	570 Nm (540 - 600 Nm)	
M 30 x 1.5	570 Nm (540 - 600 Nm)	

The torque values shown below can be achieved using a normal wheel nut spanner (vehicle tool kit) and a length of tubing.

However always check with a torque wrench as soon as possible afterwards.

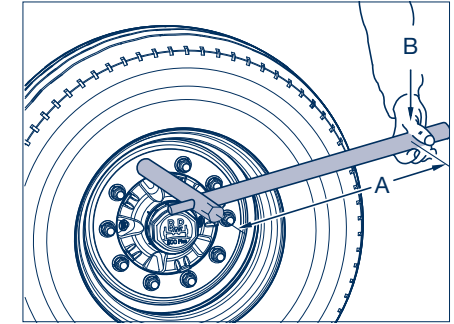

To achieve tightening torques with on-board tools

Tightening torque	Tubing length „A“	Tubing length „B“
270 - 310 Nm	300 mm	90 - 105 kg
	350 mm	78 - 89 kg
	400 mm	68 - 78 kg
320 - 350 Nm	350 mm	91 - 99 kg
	400 mm	80 - 88 kg
	450 mm	71 - 78 kg
360 - 400 Nm	500 mm	64 - 70 kg
	400 mm	90 - 99 kg
	450 mm	80 - 89 kg
440 - 480 Nm	500 mm	72 - 80 kg
	600 mm	60 - 67 kg
	700 mm	88 - 96 kg
480 - 540 Nm	600 mm	73 - 80 kg
	700 mm	63 - 69 kg
	800 mm	88 - 96 kg
600 - 660 Nm	600 mm	80 - 90 kg
	700 mm	67 - 77 kg
	800 mm	60 - 67 kg
	900 mm	85 - 95 kg
820 - 900 Nm	1000 mm	75 - 83 kg
		67 - 73 kg
		60 - 66 kg
820 - 900 Nm	1000 mm	82 - 90 kg

3 BPW Trailer axles / BPW Steering axles

3.2 Maintenance Work and Visual Inspection

3.2.2 Drum brakes

2 Check and adjust wheel brake play with manual slack adjusters

- frequent checks are necessary -
- depending upon application every 1 to 3 weeks -

Actuate slack adjusters by hand, pulling against the return spring. If there is more than 35 mm of play, the slack adjuster must be reset. This can be done by adjusting the nut on the slack adjuster as shown.

Adjust the play "a" to 10 -12% of the connected brake lever length "B", e.g. lever length 150 mm = 15 - 18 mm of play.

Automatic slack adjusters make this adjustment automatically whenever the camshaft is rotated by more than 17.5°.

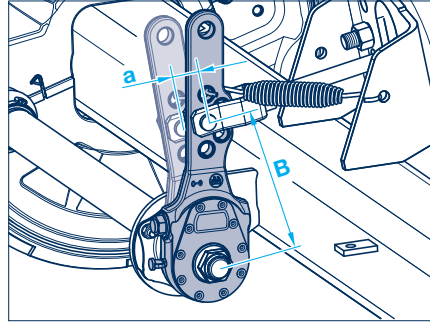

3 Check the tyres for uneven wear, adjust the inflation pressure if necessary according to the manufacturer's specifications.

- quarterly -

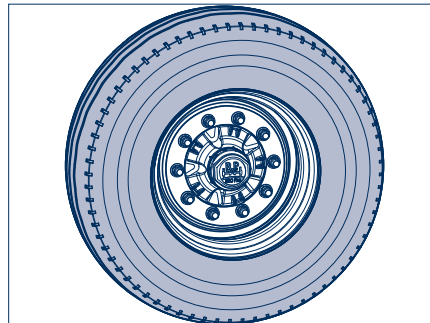

3 Check brake lining thickness

- quarterly -

Open inspection hole by folding back the rubber flap (not required with ECO Drum brakes).

The brake lining should be replaced at a residual lining thickness of 5 mm, SN 300 min. 7 mm, N 3006 min. 2.5 mm (check with slide gauge) or on reaching the bottom of the indicator machined into the edge of the lining.

Re-insert the rubber flap.

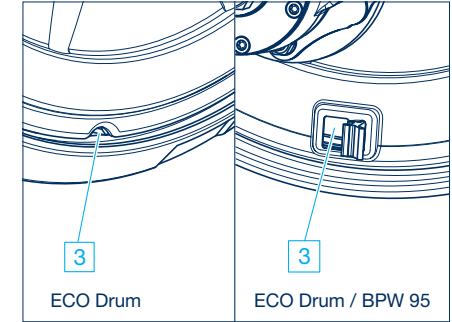

If brake lining wear indicators are fitted to the slack adjusters, the minimum thickness of the brake linings is indicated by the horizontal position of the lever (when the brake is released).

The Brake Monitor displays the "Service" signal when the wear sensor for drum brakes is installed. There is no warning function.

In certain cases the slack adjusters may not be fitted in the normal (i.e. vertical) position. In such instances, the position of the wear indicator will also be different. Linings should be changed when the wear indicator is approximately at right angles to the brake lever.

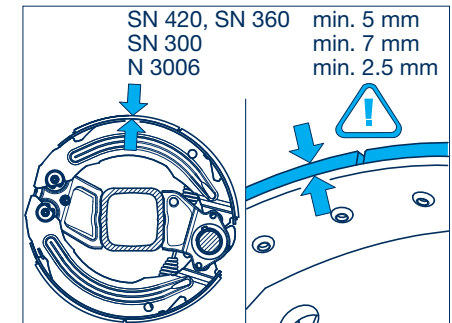
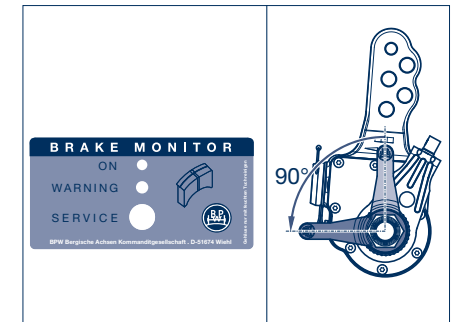

3 BPW Trailer axles / BPW Steering axles

3.2 Maintenance Work and Visual Inspection

3.2.2 Drum brakes

- 4 Check the brake drum for cracks and the internal diameter
– quarterly –

Check the condition of the brake drum and that there is adequate remaining thickness. If the wear is approaching the wear edge, measure the brake drum and renew it if the maximum permitted amount of wear has been reached.

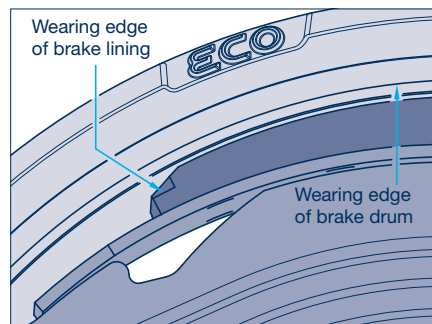

Max. amounts of wear, measured at the position with the greatest wear:

Brake	Brake shoe width (mm)	∅ Max. amount of wear (mm)	∅ Skimming size (mm)
SN 420	120 / 160	424	423
SN 420	180 / 200 / 220	425.5	424
SN 360	160 / 200	364	363
SN 300	100 / 150 / 200	304	303
FL 300	80	303	302

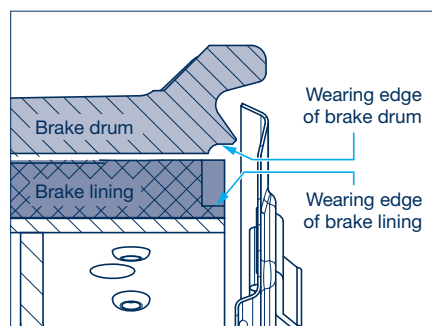
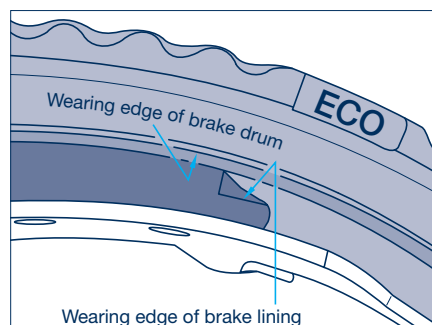

- 5 Check caps for firm seating
– every 6 months –
(not necessary with ECO Plus 3, ECO Plus 2 and ECO^{Plus} axles)

Check caps for tightness using a torque wrench or power tool. Tightening torque:

Hub caps with BPW oval shape:

ECO Plus 3 Unit	8 - 12 t	SW 110	350 Nm
ECO ^{Plus} Unit	6.5 - 12 t	SW 110	800 Nm
ECO Unit	13 - 14 t	SW 120	800 Nm

Steel hub cap for conventional bearing hub (oval)

6.5 - 9 t	SW 95	500 Nm
10 - 12 t	SW 110	500 Nm
13 - 14 t	SW 120	800 Nm
16 - 18 t	SW 140	350 Nm

Alloy cap 6 - 12 t SW 110 350 Nm

Hub cap with octagonal shape:

13 - 20 t	SW 120	700 Nm
-----------	--------	--------

In an emergency the caps can be tightened using a normal cap spanner (vehicle tool kit) by striking the latter with a hammer, or also with the aid of a piece of tubing placed over the wheel nut.

Caps with integrated hubodimeters must be fitted and dismantled using only torque controlled (DO NOT USE AIR IMPACT WRENCHES!) air guns or manually with a torque wrench.

Tighten to the correct tightening torque as soon as possible.

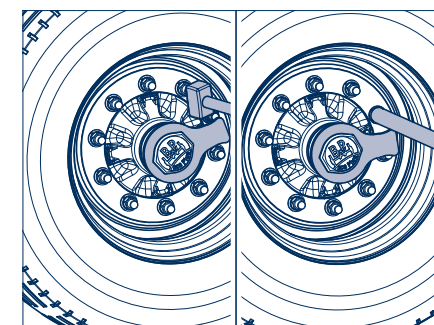
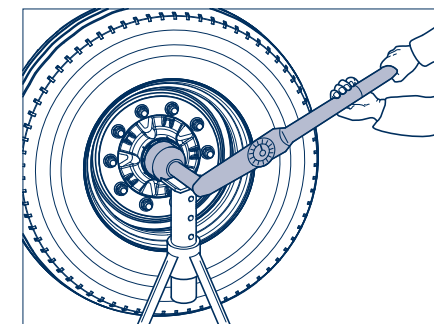

- 🔧 Caps on ECO Plus 2 axles are provided with a bayonet fitting. Check for firm seating.

Position 1: Hub cap seated loosely on the Unit.

Position 2: Hub cap seated firmly on the Unit.

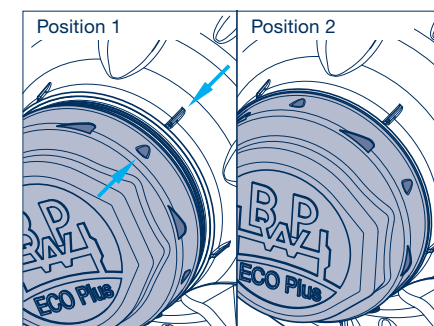

3 BPW Trailer axles / BPW Steering axles

3.2 Maintenance Work and Visual Inspection

3.2.2 Drum brakes

- 6 Check operation of the automatic slack adjusters**
 – every 6 months –
 – quarterly in use outside Europe (e.g. within the scope of the statutory checks) –

Prevent the vehicle from rolling away.
 Release the service brakes and the handbrake.

Free play check:

Operate the slack adjuster by hand or with 0.8 bar. In this case, the free play "a" corresponds to 10 - 15 % of the connected brake lever length "B", e.g. brake lever length 150 mm = free play 15 - 22 mm.

Check the adjustment if the free play is not within tolerance:

Remove rubber seal cap. Keep clutch sleeve pressed down and turn back adjustment bolt (arrow) by approx. 3/4 of a turn in a counterclockwise direction using a ring spanner. A play of at least 50 mm with a lever length of 150 mm must be available.

Actuate the brake lever several times by hand. When this is done automatic adjustment must take place smoothly. Engagement of the clutch coupling is audible and on the return stroke the adjustment bolt turns slightly in a clockwise direction. Grease with **ECO-Li^{Plus}**, see also ③ on page 9.

Fit seal cap.

Adjust the brake, see relevant workshop manual.

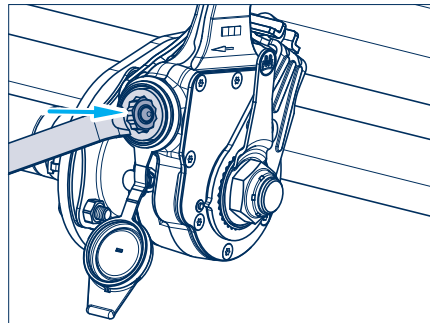
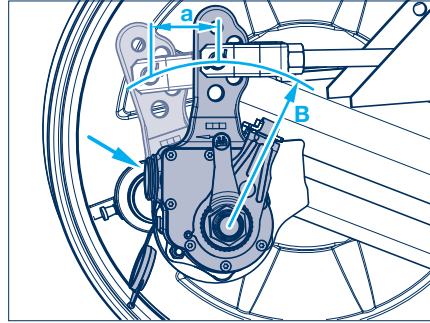

- Visual inspection**
 – every 6 months –
 – quarterly in use outside Europe –

Check all components and welding seams for damage and wear.

- 7 Check wheel hub bearing play**
 – ECO Plus 3, ECO Plus 2 and ECO^{Plus} Unit at every brake lining replacement, latest annually –
 – ECO Unit and conventional hub bearing every 6 months –

Prevent the vehicle from rolling away.

In order to check the wheel hub bearing play, lift the axle until the wheels are off the ground. Release the brake. Apply a lever between the tyre and the ground and check the play.

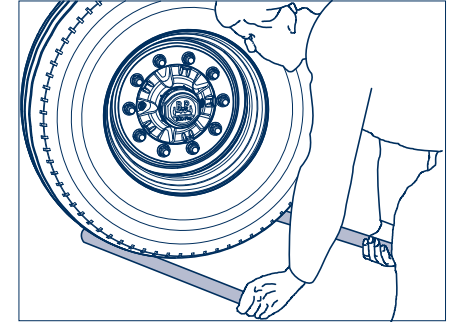

If bearing play is detected - **ECO Plus 3 Unit:**

Adjust the bearing play

1. Unscrew the cap.
2. Remove the hooked spring ring with a wedge from the axle nut.
3. Fasten axle nut using a hexagon socket spanner whilst rotating the ECO hub unit. It is necessary to turn the ECO Unit numerous times before the gearing slips over the axle nut.



Attention!
 Do not use an impact driver.

4. Fit the retaining key in the groove between the stub axle and the nut (do not reset the axle nut).
5. Insert the hooked retainer spring behind the formed edge of the axle nut.
6. Insert a new O-ring into the annular groove of the wheel hub. Apply a thin coat of BPW special long-life grease ECO-Li^{Plus} to the O-ring contact surface and thread of the hub cap.
7. Screw on the hub cap and tighten to 350 Nm.

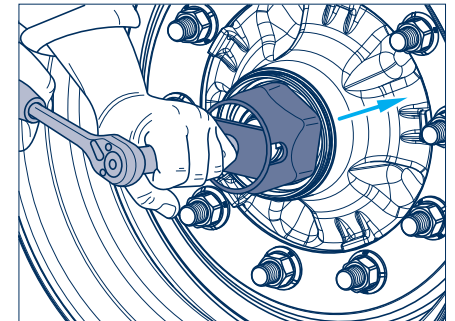
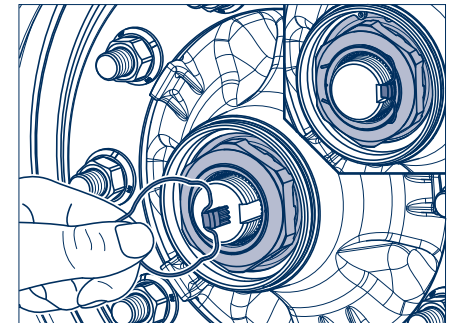

3 BPW Trailer axles / BPW Steering axles

3.2 Maintenance Work and Visual Inspection

3.2.2 Drum brakes

If bearing play is detected - **ECO Plus 2 Unit:**

Adjust the bearing play

1. Unscrew the cap with a 120 mm hub cap spanner. Undo the cap by turning it anti-clockwise by approx. 30° from position 1 to position 2.

When turned further the hub cap lifts clearly away from the ECO Unit and can be removed by pulling it away.



Attention!
Do not use an impact driver - bayonet lock.

2. Remove the hooked spring ring and retaining key from the axle bolt.

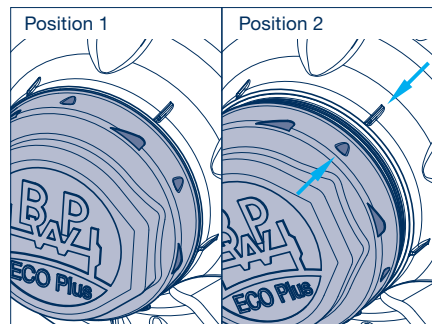
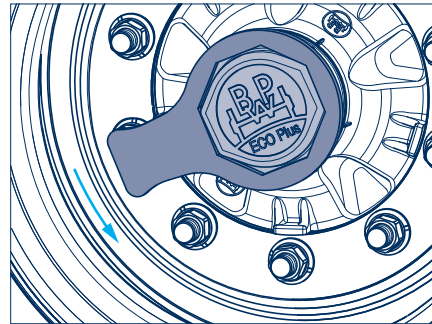

3. Tighten the axle bolt (SW 46) using a hexagon socket spanner whilst simultaneously rotating the ECO hub unit.

It is necessary to turn the ECO Unit numerous times before the gearing slips over the axle bolt.



Attention!
Do not use an impact driver.

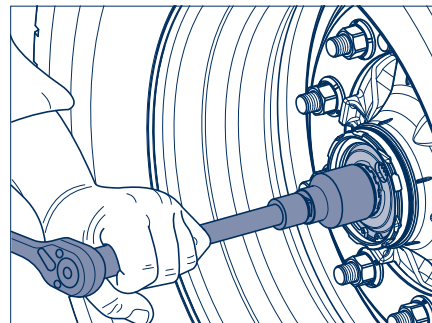

4. Insert the retaining key into the recess in the axle bolt and the gearing of the toothed lock washer (arrow). (Do not turn back the axle bolt.)

5. Insert the hooked spring ring into the groove of the hexagon profile of the axle bolt. Make sure that the hooked spring ring assembly is correctly seated in the annular groove of the axle bolt.

6. Insert a new O-ring into the groove in the wheel hub.

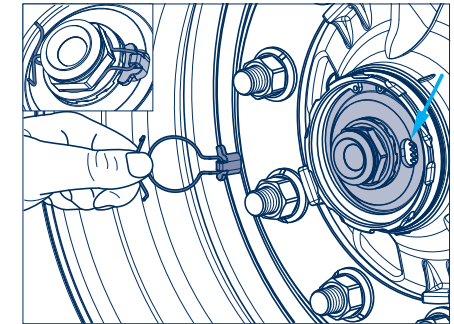

7. Apply a thin layer of BPW ECO-Li^{Plus} special longlife grease to the hubcap in the area of the O-ring contact surface and the bayonet fitting.

8. Screw on the cap with a 120 mm cap spanner.



Attention!
Do not use an impact driver - bayonet lock.

Push on the hubcap, see position 1. Press on the hubcap and turn it by approx. 30° in a clockwise direction to lock it in place. A tight seat is provided when position 2 is reached.

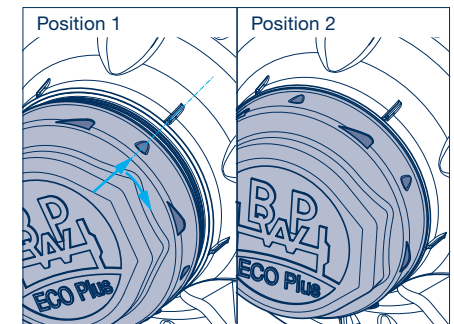

3 BPW Trailer axles / BPW Steering axles

3.2 Maintenance Work and Visual Inspection

3.2.2 Drum brakes

If bearing play is detected - **ECO^{Plus} Unit:**

Adjust the bearing play

1. Unscrew the cap.
2. Remove the hooked spring ring with a wedge from the axle nut.
3. Fasten axle nut using a hexagon socket spanner whilst rotating the ECO Unit. It is necessary to turn the ECO Unit numerous times before the gearing slips over the axle nut.



Attention!
Do not use an impact driver.

4. Fit the retaining key in the groove between the axle stub and the nut (do not reset the axle nut).
5. For production date April 2000 onwards, insert the hooked spring ring behind the edge of the axle nut or, up to March 2000, into the thread on the axle stub.
6. Tighten the cap to 800 Nm.

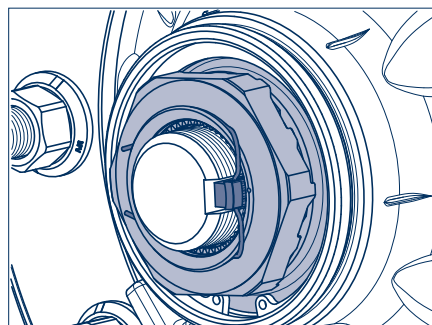
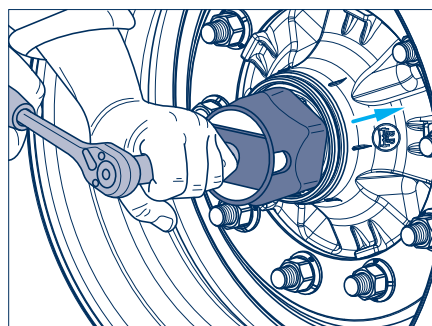
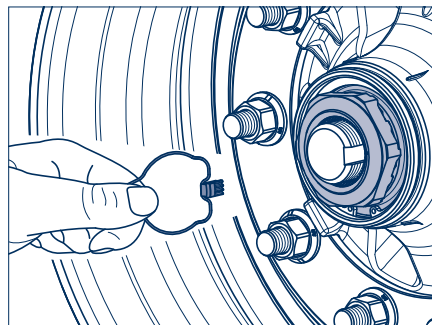

If bearing play is detected - **ECO Unit:**

Adjust the bearing play

1. Unscrew the cap.
2. Loosen axle nut.
3. Fasten axle nut using a torque wrench whilst rotating the ECO hub unit. It should take several turns until the tightening torque has reached 150 Nm.
 - If a normal axle nut spanner is used (vehicle tool kit), tighten the axle nut until the ECO Unit drags slightly (auxiliary solution).
4. Turn back axle nut to the next locking position (max. 15°). The asymmetrical cap of the axle nut enables the next locking position to be reached after turning back max. 15°.

5. Insert bolt and locking ring.

6. Screw on caps.

Tightening torque:

Steel / cast cap	800 Nm
Aluminium cap	350 Nm

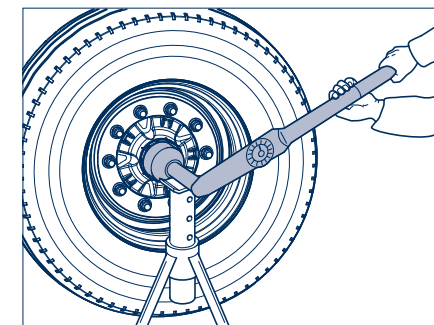
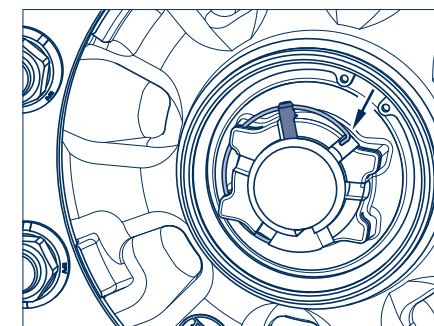
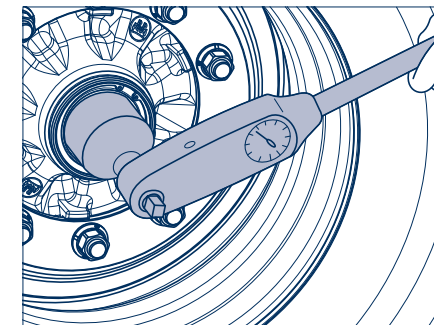

3 BPW Trailer axles / BPW Steering axles

3.2 Maintenance Work and Visual Inspection

3.2.2 Drum brakes

If bearing play is detected
- **conventional hub bearing:**

Adjust the bearing play

1. Unscrew the cap.
2. Remove the split pin from the axle nut.
3. Fasten the axle nut using a torque wrench and with the continuous turning of the wheel hub. It should take several turns until the tightening torque has reached the desired value.

Tightening torques:

hub caps with BPW oval shape:

Up to an axle load of 5.5 tons (up to calendar week 38/2011) = 100 Nm,
from 6 to 18 tons axle load = 150 Nm,

hub caps with octagonal shape:

from 16 to 30 tons axle load = 350 Nm

- If a normal axle nut spanner is used (vehicle tool kit), tighten the axle nut until the wheel bearing race drags slightly.

4. Turn back the axle nut to the next available split pin hole. Should they already be in line turn back to the next hole (30° at the maximum). (Does not apply to the ECO Plus 3, ECO Plus 2, ECO^{Plus} and ECO Unit.)

5. Insert the split pin and bend upwards slightly.

6. Refill the cap as required with BPW special longlife grease ECO-Li^{Plus} and replace.

For tightening torques see point [5](#) on page 31.

 For 16 - 18 t axles with BPW oval shape hub cap, a new O-ring must be fitted on reassembly.

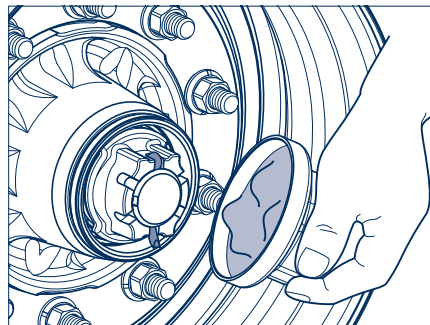
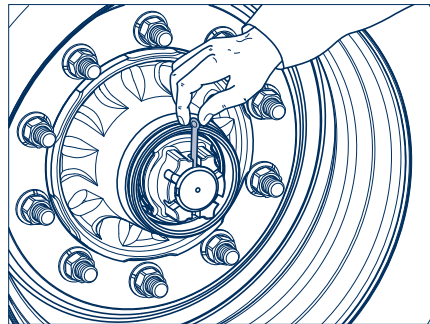
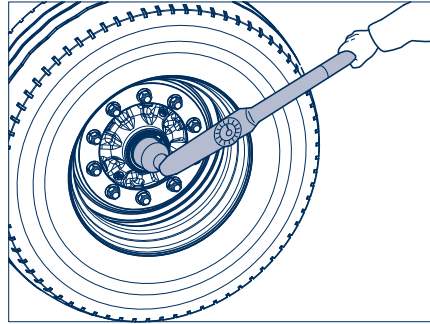

If bearing play is detected
- **conventional hub bearing up to 5.5 t,
from calendar week 38/2011:**

Adjust the bearing play

1. Unscrew the cap.
2. Remove the split pin from the axle nut.
3. Tighten the axle nut with a torque wrench at the same time with continuous rotation of the wheel hub. Minimum 5 rotations must be done until a torque of 100 Nm is achieved.
4. Loosen the axle nut with two full turns until the bearing is loosened or relaxed.
5. If necessary screw hub puller. Complete wheel hub unit with BPW hub puller 05.012.25.01.0 and screw 02.5026.50.80 or alternatively retrieve a universal hub puller to relax the bearing.
6. Tighten using 70 Nm axle nut.
7. Check the wheel bearing can run freely. It must be possible to turn the wheel hub evenly and without any noticeable restraint after having been set.
8. Turn back axle nut to the next locking position (min. 3°, max. 15°). Through the asymmetric cap of the axle nut, the next locking position is reached after turning back max. 15°.
9. Insert pin and locking ring.
Take care to ensure the hooked spring ring is located correctly within the axle nut.
10. Mark the position of the axle nut on the axle stub (arrow).
11. Refill the hub cap as required with BPW special longlife grease ECO-Li^{Plus} and replace.
Tightening torque: 500 Nm

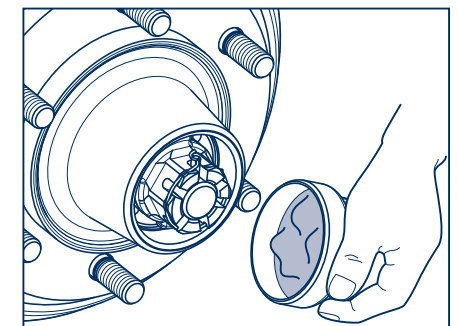
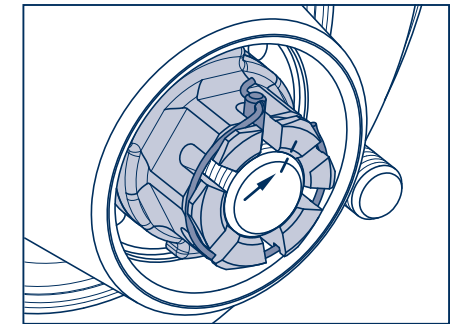
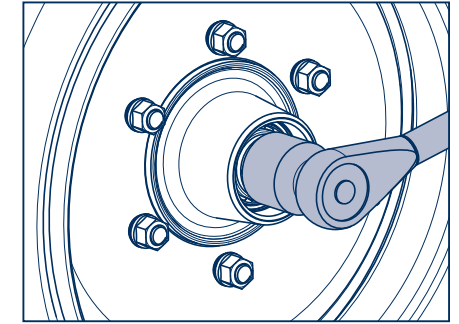

3 BPW Trailer axles / BPW Steering axles

3.2 Maintenance Work and Visual Inspection

3.2.3 Disc brakes, brake types: TSB 3709, TSB 4309, TSB 4312

Overview	Initially	Every 12 weeks ¹⁾	Every 26 weeks ¹⁾	At every brake lining replacement, latest annually
For detailed description, see pages 42 - 48 Disc brakes type SB, see pages 50 - 62 Air suspension, see pages 64 - 84 Suspension, see pages 86 - 95				
Maintenance work - Disc brakes Brake type: TSB 3709, TSB 4309, TSB 4312				
1 Check wheel nuts for tightness.	1 ²⁾			
2 Check brake pad thickness.		2		
- Visual check, check all components and welding seams for damage, wear and corrosion.			-	
3 Check brake disc thickness and visually check for cracks.		3 ³⁾	3	
4 Check caliper guide system.		4 ³⁾	4	
5 Check coarse dirt seals and the pressure plates.			5 ³⁾	5
6 Check the bearing play of the ECO Unit, adjust if necessary.				6

¹⁾ Under extreme conditions, increase frequency (e.g. Off-Road, heavy-duty braking work).

²⁾ After the first run under load conditions and likewise after each wheel change.

³⁾ For use outside Europe.

Note: Components that have damages due to improper mounting are to be exchanged after a review by a BPW Service Centre.

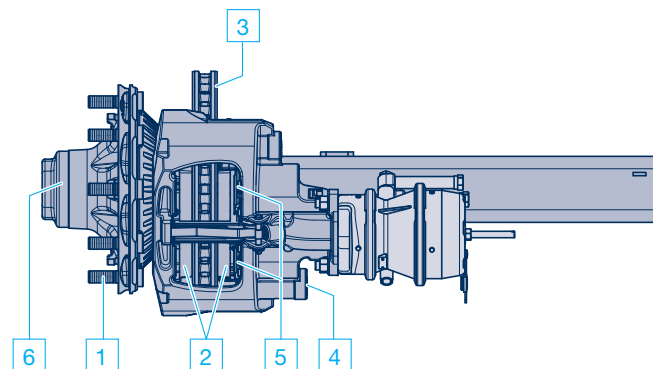

Series SH with disc brakes type TSB

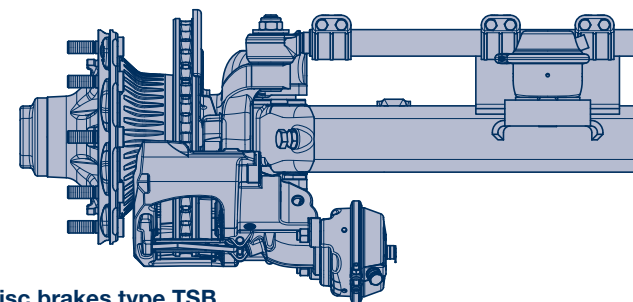

Series LL with disc brakes type TSB

3 BPW Trailer axles / BPW Steering axles

3.2 Maintenance Work and Visual Inspection

3.2.3 Disc brakes, brake types: TSB 3709, TSB 4309, TSB 4312

1 Check wheel nuts for tightness

– the tightening torque of the wheel nuts must be checked after the first laden load journey as well as after each wheel change and, if appropriate, retightened to the prescribed value –

Tighten wheel nuts diagonally using a torque wrench to the correct tightening torque.



It is imperative that the prescribed tightening torques are adhered to in order to ensure the wheels are securely fastened!

The wheel studs must be clean and free of damage and the nuts must be easily tightened and loosened. If needed, lightly oil the contact surface between the wheel nut and the pressure disc. Do not oil or grease the thread of the wheel studs and wheel nuts.

Tightening torques for wheel nuts M 22 x 1.5:

Stud alignment : **510 Nm** (485 - 535 Nm)

Spigot alignment: **630 Nm** (600 - 660 Nm)

Attention: Do not exceed specified settings!

Wheel contact surface should not have additional coats of paint (risk of the wheels becoming detached)!

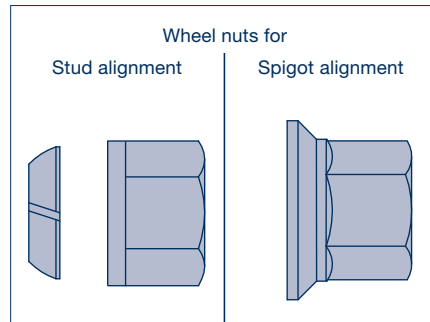
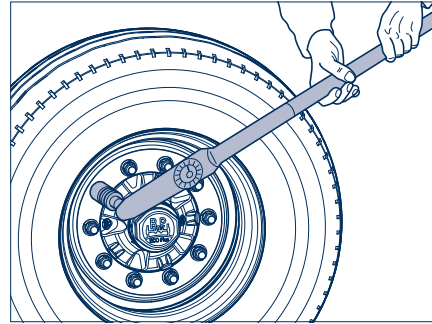

2 Check brake pad thickness

– quarterly –

The brake pad thickness must be checked regularly, e.g. during the tyre inflation pressure check. The intervals must not be more than 3 months.

The brake pad thickness can be checked where the brake caliper interfaces with the welded anchor plate with the wheels mounted (approximate wear indicator).

Dimension x (distance between brake caliper and brake anchor plate):

9 mm => when new

TSB 3709 / 4309

30 mm => max. permissible brake pad wear, 21 mm

34 mm => max. permissible wear for brake pad and brake disc

TSB 4312

28 mm => max. permissible brake pad wear, 19 mm

32 mm => max. permissible wear for brake pad and brake disc

The brake pads must be removed to inspect them more closely - see relevant workshop manual.

Heat affected, glazed over, or oily brake pads must be replaced immediately.

The remaining brake pad thickness must **not** be less than 2 mm (use a caliper gauge for this).

Hairline cracks at the edges are permissible; replacement is required if more sizable surface cracks are present.

- Visual inspection

– every six months –

Check all components and welding seams for damage, wear and corrosion.

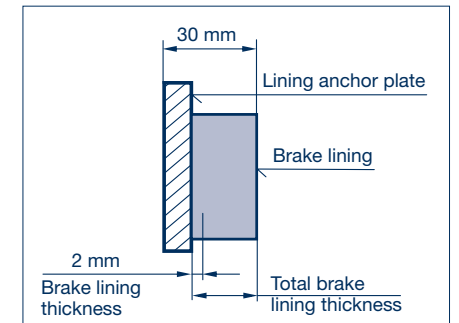
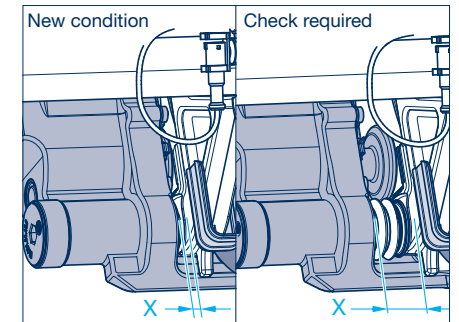
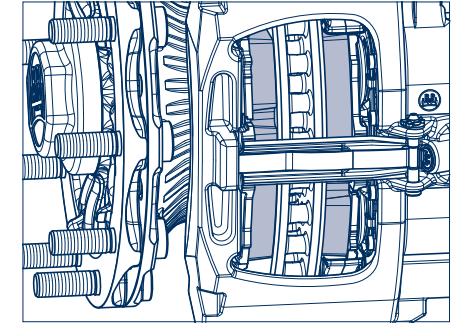

3 BPW Trailer axles / BPW Steering axles

3.2 Maintenance Work and Visual Inspection

3.2.3 Disc brakes, brake types: TSB 3709, TSB 4309, TSB 4312

- 3 Brake disc**
(Check the condition of the brake disc)
 – every 6 months when used within Europe,
 quarterly when used outside Europe –

Sections **A - D** (see fig.) show the possible conditions of the disc surface:

- A:** Network-type tears = permissible
B: Radial cracks up to max. 1.5 mm width and depth = permissible
C: Uneven disc surface less than 1.5 mm = permissible
D: Continuous cracks = not permissible

Technical details:

- Disc thickness, new = 45 mm
- Minimum permissible disc thickness = 37 mm
 (Use a caliper gauge where the pads make contact)

In the case of surface conditions **A - C**, the brake disc can be used until the minimum permissible disc thickness has been reached.

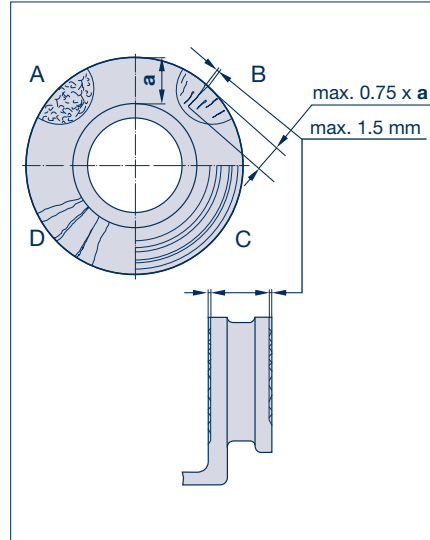

Attention!

To prevent damage to the brake discs, the brake pads should be replaced when the minimum thickness (excluding backing plate) is **2 mm** or less.

Brake discs should always be replaced in pairs. The brake pads should also be replaced when new brake discs are fitted.

If this instruction is not adhered to, there is a danger that with the worn brake pads the brake disc will be damaged and the braking performance could be seriously reduced.

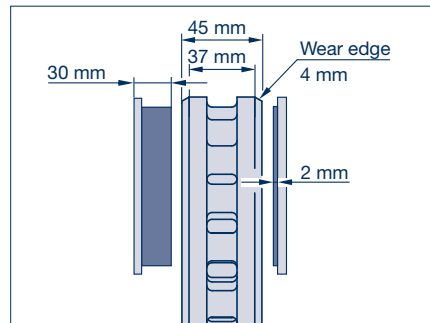

- 4 Checking the brake caliper guide system**
(check play and adjustment)
 – every 6 months when used within Europe,
 quarterly when used outside Europe –
 (e.g. within the scope of the statutory checks)

Prevent the vehicle from rolling away.
Release the service and parking brakes.

The brake cylinder and fasteners for the brake pads can remain fitted.

Forcefully push the sliding caliper in the axle direction. The caliper must move approximately 0.7 to 1.3 mm (play).

If play is not within this tolerance, the brake caliper guide must be checked and readjusted.

For close inspection of play with wheels mounted:

Use a dial gauge to determine the play. To this end, attach a dial gauge holder to the axle housing and position the button on the outside of the screw plug (1) or on the brake cylinder.

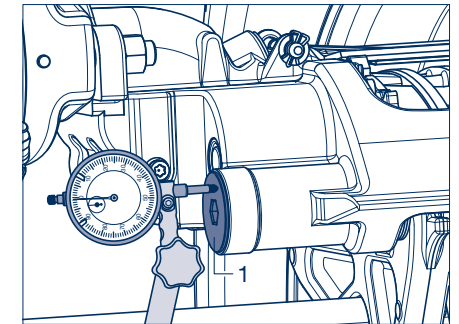
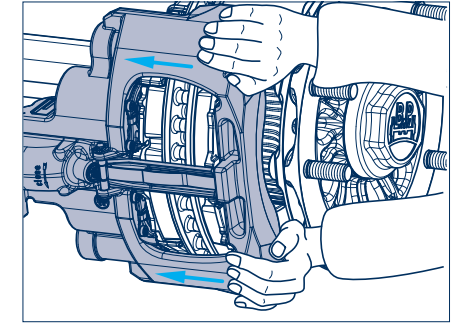

For close inspection of play with wheels removed:

Check the play using two feeler gauges.

Forcefully push the sliding caliper towards the centre of the axle and insert the gauges between the pressure plates (2) and pad backing plate (3).

If play is not within the tolerance required, adjustment must be carried out and the brake caliper guide checked.

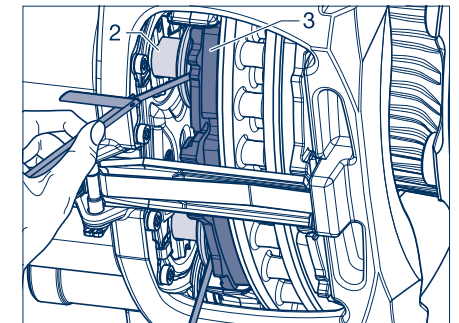

3 BPW Trailer axles / BPW Steering axles

3.2 Maintenance Work and Visual Inspection

3.2.3 Disc brakes, brake types: TSB 3709, TSB 4309, TSB 4312

Set play and check adjustment

1. Remove the plug.
2. Using a torx wrench (T25), depress the return spring and turn clockwise until it „clicks“ 2 times.
3. Actuate the brake 5 to 10 times with a force of approximately 2 bar.
4. Forcefully push the sliding caliper in the axle direction. The play exhibited at this time must be between 0.7 and 1.3 mm.
Adjustment is correct if play is within this tolerance.
5. Reinsert the plug.

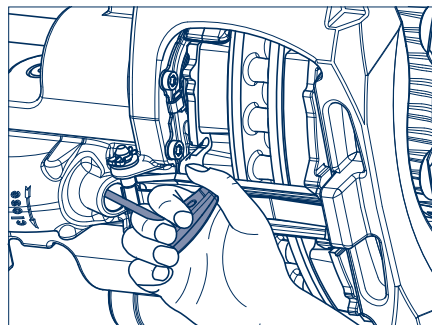

Check brake caliper guide:

The brake caliper guide must be checked if the play was not adjusted properly.

The guide bushings are sealed by the bellows (4) and the screw plug (1).

Inspect the bellows and sealing plugs for cracks, damage and proper seating and replace if necessary.
Sealing plugs that have been removed must be replaced, not re-used.

See workshop manual ECO Disc for information on how to repair the brake caliper guide.

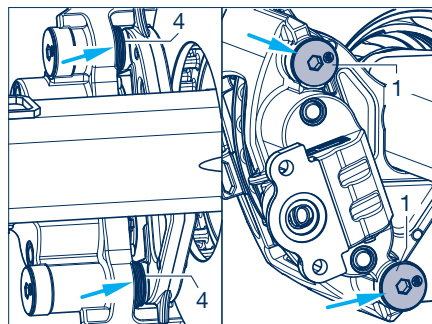

Check the brake caliper bearing play:

The bearing play of the brake caliper can be established using a dial gauge. Attach the dial gauge holder to the axle beam and position the gauge, facing the long locating bearing, on the lower edge of the cylinder flange.

Press the brake caliper on the brake cylinder vertically **downwards** to its installation position and set the dial gauge to „zero“. Press the brake caliper **upwards** and read the bearing play on the dial gauge. If a brake caliper bearing play exceeds 1.5 mm, the brake caliper bearing must be replaced.

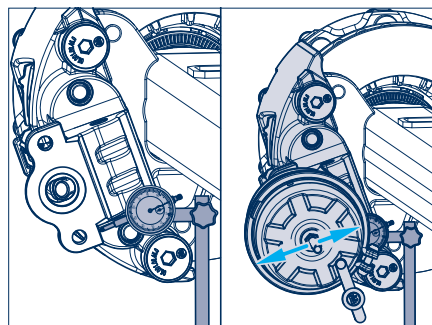

5 Check coarse dirt seals and the tappets

- at every brake lining replacement, latest annually in Europe –
- every six months in use outside Europe –

Prevent the vehicle from rolling away.
Release the service and parking brakes.

See workshop manual ECO Disc for information on how to remove the brake pads.

The service brake and spring actuator must be released.

With a vernier gauge, measure the diameter of the concentric pin on the two thrust pieces.

When it reaches a minimum of 8 mm, change the thrust piece.

To change the thrust piece, see workshop manual ECO Disc.

Unscrew the tappets beyond the adjuster (min. 30 mm) until the coarse dirt seals are plainly visible.

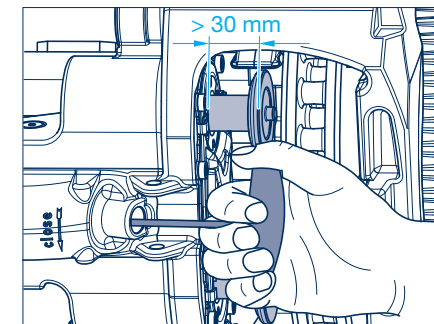
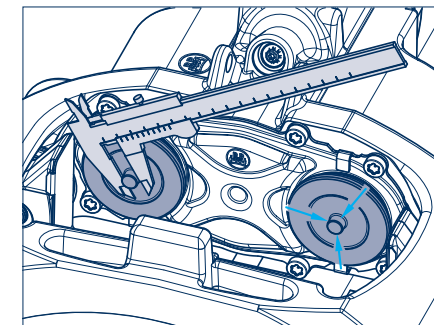

Ensure proper seating.
(Visual inspection, see detail extract)

Check the dust cover of the brake caliper in the area between the coarse dirt seals (arrows) for deformation. If deformation is detected, the brake caliper requires changing!

Note:
Penetrating dirt and damp cause corrosion and affect the operation of the clamping mechanism and adjustment.

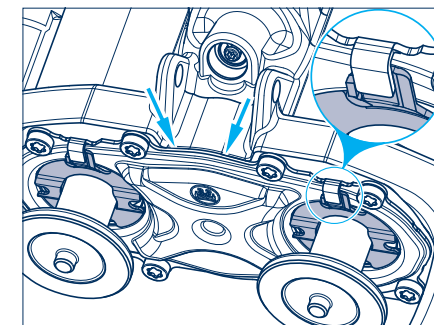

3 BPW Trailer axles / BPW Steering axles

3.2 Maintenance Work and Visual Inspection

3.2.3 Disc brakes, brake types: TSB 3709, TSB 4309, TSB 4312

The bellows must be replaced if thermal overloading was detected.

Only new parts may be used.

The adjustment device must be checked for corrosion and ease of movement before the new parts are installed.

See workshop manual ECO Disc for information on how to replace the bellows.

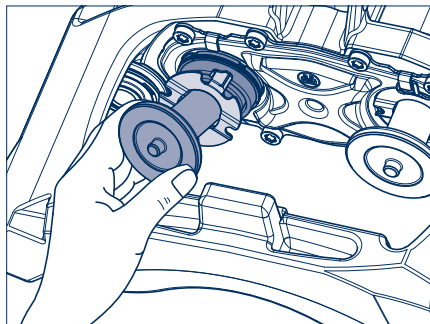

6 Check the bearing play of the ECO Unit – at every brake lining replacement, latest annually –

Prevent the vehicle from rolling away.

In order to check the bearing play of the ECO Unit, lift the axle until the wheels are off the ground. Release the brake. Apply a lever between the tyre and the ground and check the play.

The bearing play must be reset if the bearing play can be felt.

See instructions on setting bearings for ECO Plus 3, ECO Plus 2 and ECO^{Plus}, pages 33 to 36.

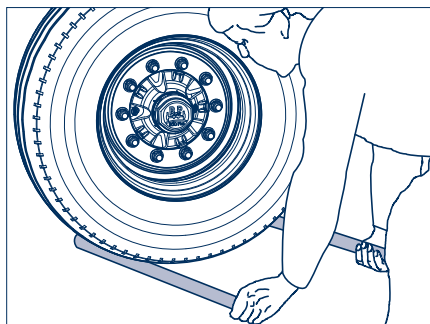

3 BPW Trailer axles / BPW Steering axles

3.2 Maintenance Work and Visual Inspection

3.2.4 Disc brakes, brake types: SB 3308, SB 3745, SB 4309, SB 4345

Overview		Initially	Every 12 weeks	Every 26 weeks ²⁾	At every brake lining replacement, latest annually ²⁾
For detailed description, see pages 52 - 62 Disc brakes type TSB, see pages 40 - 48 Air suspension, see pages 64 - 84 Suspension, see pages 86 - 95					
Maintenance work - Disc brake Brake type: SB 3308, SB 3745, SB 4309, SB 4345					
1	Check wheel nuts for firm seating.	1 ¹⁾			
2	Check brake pad thickness.		2		
-	Check the tyres for uneven wear, adjust the inflation pressure if necessary according to the manufacturer's specifications.		-		
o	Visual check of all components and welding seams for damage, wear and corrosion.			o	
3	Check brake disc thickness and visually check for cracks.		3 ³⁾	3	
4	Check brake adjustment.		4 ³⁾	4	
5	Check caliper guide system.		5 ³⁾	5	
6	Check bellows on the guide pins. - ECO Plus 2 and ECO ^{Plus} axles - ECO axles and axles with conventional hub bearing			6 ³⁾ 6	6
7	Check caliper unit. - ECO Plus 2 and ECO ^{Plus} axles - ECO axles and axles with conventional hub bearing			7 ³⁾ 7	7
8	Check wheel hub bearing play, adjust if necessary. - ECO Plus 2 and ECO ^{Plus} Unit - ECO Unit and conventional hub bearing			8	8
9	Check caps for tightness. (not necessary with ECO Plus 2 and ECO ^{Plus} axles)			9	

¹⁾ After the first run under load conditions, likewise after each wheel change.

²⁾ Under extreme conditions, increase frequency (eg. construction sites and poor roads).

³⁾ For use outside Europe.

Note: Components that have damage due to improper mounting are to be exchanged after a review by a BPW Service Centre.

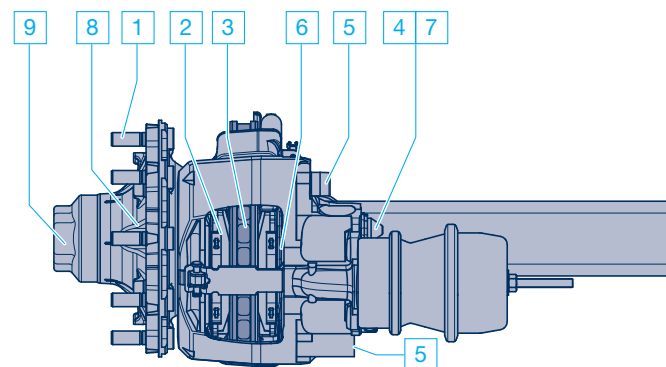

Series SH / SKH with disc brakes type SB

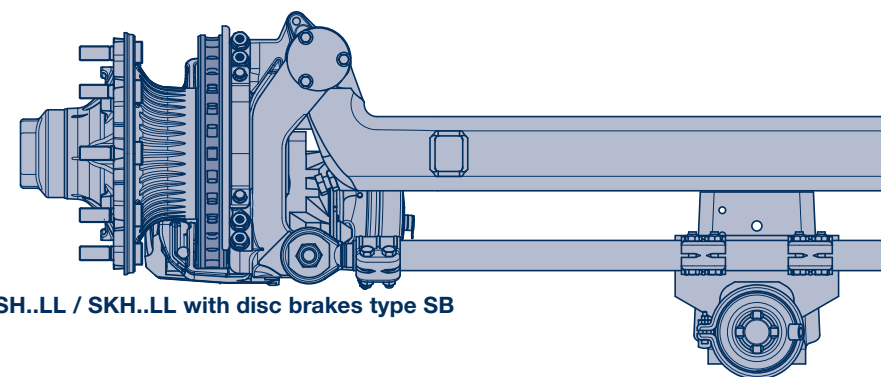

Series SH..LL / SKH..LL with disc brakes type SB

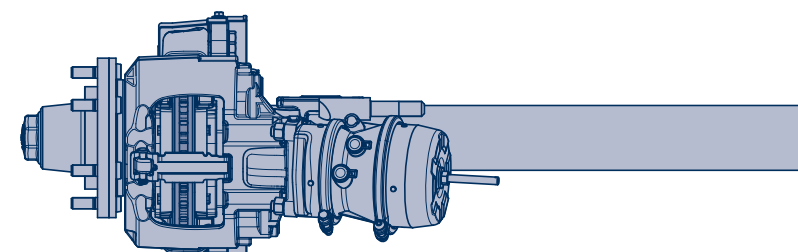

Series SNR with disc brakes type SB

3 BPW Trailer axles / BPW Steering axles

3.2 Maintenance Work and Visual Inspection

3.2.4 Disc brakes, brake types: SB 3308, SB 3745, SB 4309, SB 4345

1 Check wheel nuts for tightness

– the tightening torque of the wheel nuts must be checked after the first laden load journey as well as after each wheel change and, if appropriate, retightened to the prescribed value –

Tighten wheel nuts diagonally using a torque wrench to the correct tightening torque.



It is imperative that the prescribed tightening torques are adhered to in order to ensure the wheels are securely fastened!

The wheel studs must be clean and free of damage and the nuts must be easily tightened and loosened. If needed, lightly oil the contact surface between the wheel nut and the pressure disc. Do not oil or grease the thread of the wheel studs and wheel nuts.

Tightening torques for wheel nuts:

M 18 x 1.5
 Stud alignment: **290 Nm** (275 - 305 Nm)
 Spigot alignment: **350 Nm** (330 - 370 Nm)

M 22 x 1.5:
 Stud alignment: **510 Nm** (485 - 535 Nm)
 Spigot alignment: **630 Nm** (600 - 660 Nm)

Attention: Do not exceed specified settings!

Wheel contact surface should not have additional coats of paint (risk of the wheels becoming detached)!

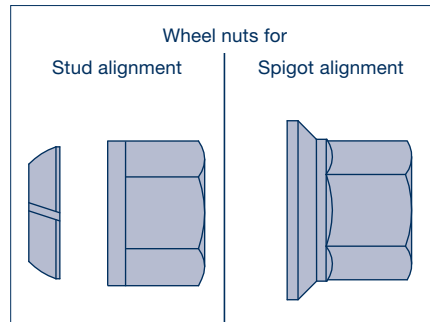
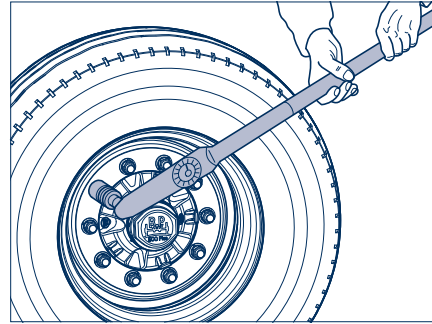

2 Check brake pad thickness SB 3745 / SB 4309 / SB 4345

– quarterly –

The brake pad thickness must be checked regularly, e.g. during the tyre inflation pressure check. The intervals must not be more than 3 months.

The thickness of the remaining pad must **not be less than 2 mm** (check with slide gauge).

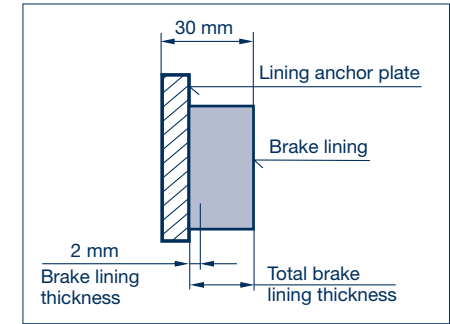

Open bearing:

The thickness of the brake pad can be checked by the position of the brake caliper (1) in relation to the guide rod (2) (approximate indication of wear) with the wheels attached.

If the end of the guide sleeve (3) is level with the fixed guide rod, the pad thickness must be checked again after the wheels have been removed.

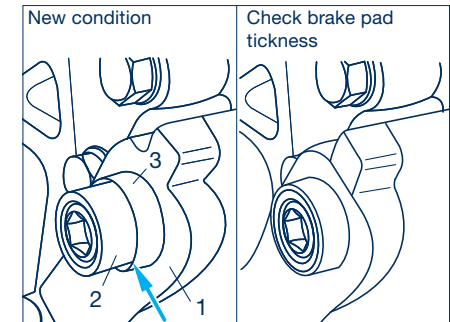

Sealed bearing:

The sealed bearing has a ridged rubber seal which is fitted over the guide pin. Pad wear should be checked when the wear mark (transition point between the ridged and smooth areas - see diagram) has moved to the end of the guide pin.

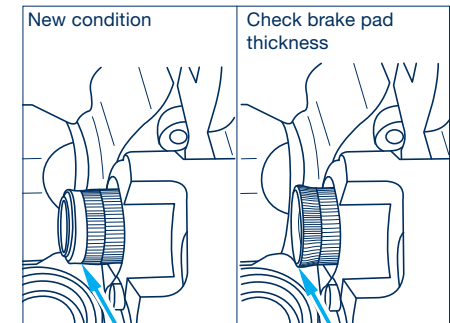

3 BPW Trailer axles / BPW Steering axles

3.2 Maintenance Work and Visual Inspection

3.2.4 Disc brakes, brake types: SB 3308, SB 3745, SB 4309, SB 4345

Check brake pad thickness

SB 3308

– quarterly –

The brake pad thickness must be checked regularly, e.g. during the tyre inflation pressure check. The intervals must not be more than 3 months.

The thickness of the remaining pad must **not be less than 2 mm** (check with slide gauge).

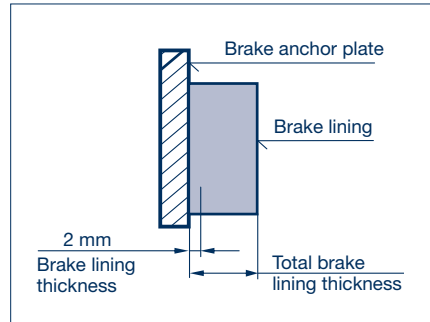

The brake pad thickness can be checked with the wheels attached by means of the position of the brake caliper marking (P) in relation to the fixed brake carrier flange (R).

On reaching the status as shown in the illustration below right, the brake pad thickness and the brake disc must be checked with the wheel removed.

Replace the brake pads and/or brake disc as necessary.

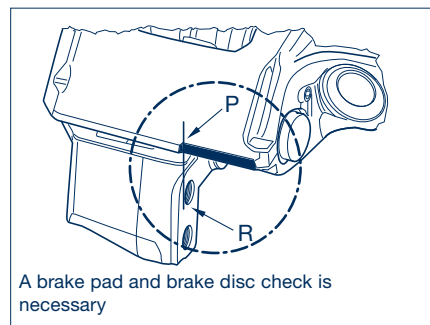
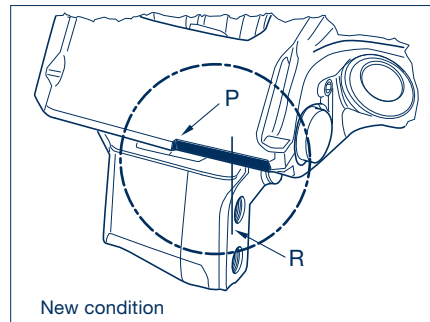

A brake pad and brake disc check is necessary

- Check the tyres for uneven wear and adjust the inflation pressure if necessary according to the manufacturer's specifications
– quarterly –

- o Visual inspection
– every six months –

Check all components and welding seams for damage, wear and corrosion.

3 Brake disc (Check the condition of the brake disc)

- every 6 months –
- quarterly in use outside Europe –

Section A - D (see fig.) show the possible conditions of the disc surface:

A: Network-type tears = permissible

B: Radial cracks up to max. 1.5 mm width and depth = permissible

C: Uneven disc surface less than 1.5 mm = permissible

D: Continuous cracks = not permissible

In the case of surface conditions A - C the brake disc can be used until the minimum permissible disc thickness has been reached.

Attention!

To prevent damage to the brake discs, the brake pads should be replaced when their thickness (excluding backing plate) is **2 mm** or less.

If this instruction is not adhered to, there is a danger that with the worn brake pads the brake disc will be damaged and the braking performance could be seriously reduced.

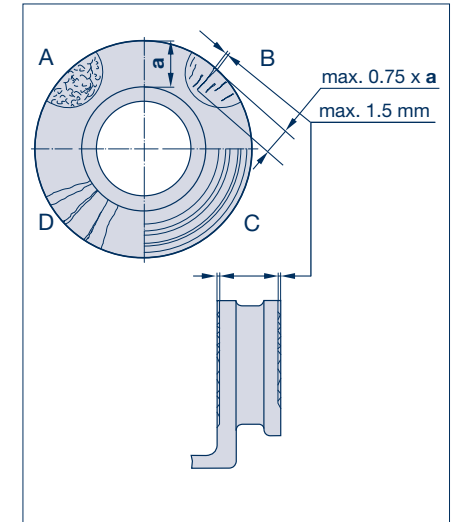

3 BPW Trailer axles / BPW Steering axles

3.2 Maintenance Work and Visual Inspection

3.2.4 Disc brakes, brake types: SB 3308, SB 3745, SB 4309, SB 4345

SB 3745 / SB 4309 / SB 4345

Technical details:

- Disc thickness, new = 45 mm
- Minimum permissible disc thickness (check with slide gauge) = 37 mm

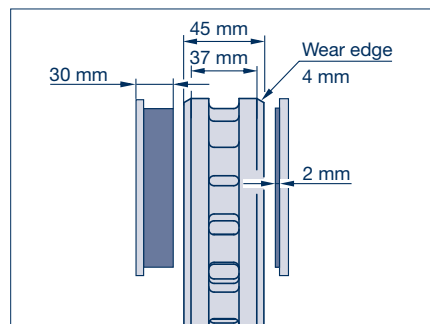

SB 3308

Technical details:

- A Disc thickness, new = 34 mm
- minimum permissible disc thickness (check with slide gauge) = 28 mm
- C1 Overall thickness of new brake pad = 27 mm
- C2 Overall thickness of new brake pad = 34 mm
- D1 Pad backing plate = 8 mm
- D2 Pad backing plate = 15 mm
- E Brake pad minimum thickness = 2 mm
- F1 Brake pad minimum thickness incl. pad backing plate = 10 mm
- F2 Brake pad minimum thickness incl. pad backing plate = 17 mm

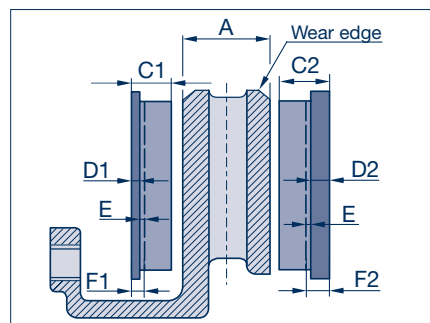

4 Check adjustment

- every 6 months -
- quarterly in use outside Europe -

Prevent the vehicle from rolling away.
Release the service brakes and the handbrake.

SB 3308

Remove wheel. Remove pad retainer clip. Pull the brake caliper on its guide pins in the direction of the outside of the vehicle.

Using a suitable tool, press the outer brake pad in the direction of the tappet. Measure the gap between the backing plate and the inside of the caliper. This must be between 0.6 and 1.1 mm.

Attention!

If the air gap is too large, the braking effect may fail.
If the air gap is too small, brake may overheat and cause further damage.

If the air gap is too big or too small, the adjustment must be checked as follows:

SB 3308 / SB 3745 / SB 4309 / SB 4345

Remove cap.
Place a ring spanner size 8 on the hex. profile of the adjuster, or a spanner size 10 on the adjuster adapter. Turn anti-clockwise until the ratchet clicks 3 or 4 times.

Attention!

If the version has an adjustment adapter, never turn without the adapter. Exceeding the specified break-off torque of the adapter will cause the adapter to break.

Repeat with a new adapter. Fit a new brake caliper if the adapter shears off again - this is an indication of internal damage.

Do not use an open-ended spanner.

Max. torque: approx. 25 Nm

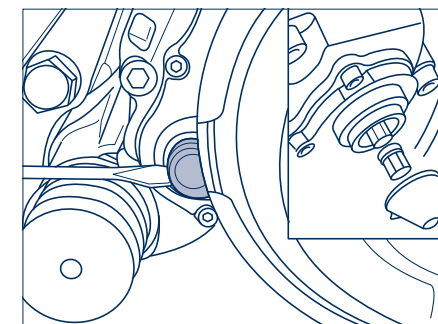
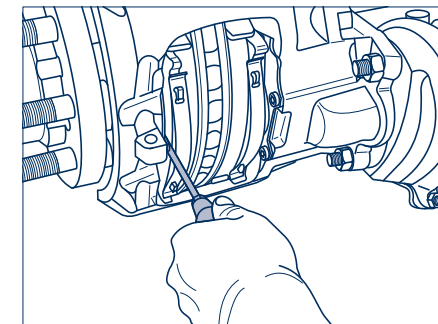

3 BPW Trailer axles / BPW Steering axles

3.2 Maintenance Work and Visual Inspection

3.2.4 Disc brakes, brake types: SB 3308, SB 3745, SB 4309, SB 4345

Apply brake 5 to 10 times (approximately 2 bar). If the adjustment is correct, the ring spanner will turn back in a clockwise direction (make sure the ring spanner can rotate freely).

Note: As the cycle rate increases, the movement of the ring spanner, becomes smaller.

If the ring spanner moves as described, the adjustment is then OK.

Remove ring spanner.

Apply **Renolit HLT2** to the cap and re-fit. For the version with the adapter, fit the lug on the cap pointing towards the axle beam.

The adjuster or the ring spanner:

- does not turn,
- turns only upon initial application,
- turns forward and back again upon each application,

the adjustment is not correct and the brake caliper must be replaced.

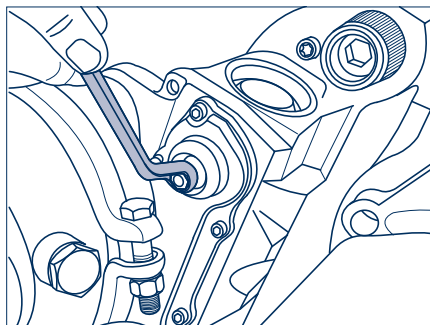

5 Check the brake caliper guide system

- every 6 months –
(e.g. within the scope of the statutory checks)
- quarterly in use outside Europe –

Prevent the vehicle from rolling away.
Release the service brakes and the handbrake.

Apply considerable pressure to the sliding caliper in the direction of the guide bearing. It should be possible to move it by about 0.5 to 1 mm (play). Check the brake caliper guide if this is not the case.

SB 3745 / SB 4309 / SB 4345

The guide bush (1a) is sealed by the bellows (2) and the sheet metal cap (3) with the sealing ring (4).

Parts (2) and (3) must not be split or damaged in any way. If necessary, replace. Check for correct fitting.

If the version has a guide sleeve (5), check it for damage and to make sure it is correctly seated.

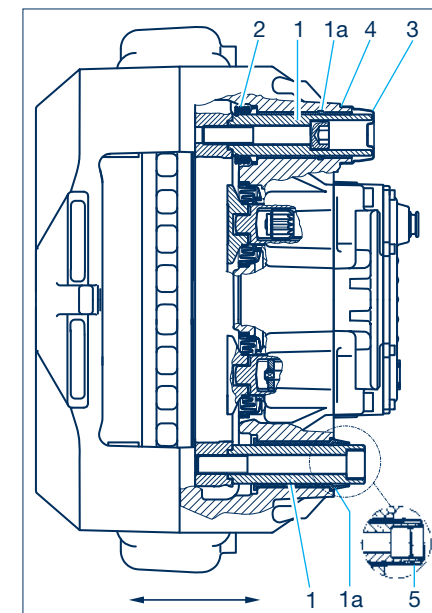

SB 3308

Ability of the caliper to slide to the full extent of the caliper guides:

Remove the brake pads. Fully retract the tappet (7) by turning the adjuster in an anti-clockwise direction, using an adapter.

It must be possible to slide the brake caliper (6) by hand over the entire distance of more than 20 mm on the guide pieces (8) and (9) as well as (10) and (11), without using any tools.

Check caliper guide seals:

The guide bushes (8) and (10) are sealed by means of the bellows pieces (12) and (13). These parts must not show any cracks or damage. Check that everything is properly seated.

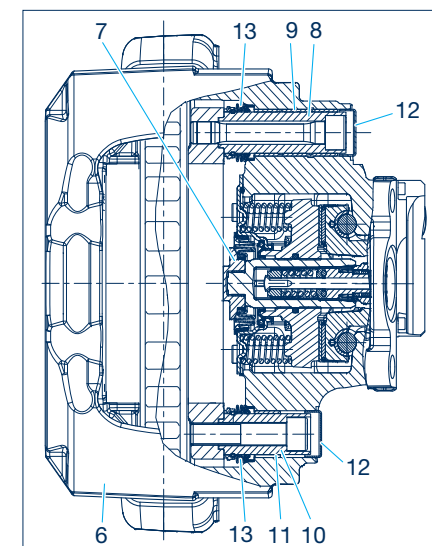

3 BPW Trailer axles / BPW Steering axles

3.2 Maintenance Work and Visual Inspection

3.2.4 Disc brakes, brake types: SB 3308, SB 3745, SB 4309, SB 4345

6 Bellows at the thrust pieces

- ECO Plus 2 and ECO^{Plus} axles, when used within Europe, at every brake pad change or every year at the latest; every six months outside Europe –
- ECO axles and axles with conventional mounting, every six months –

Prevent the vehicle from rolling away.
Release the service brakes and the handbrake.

Remove the brake pads, if necessary.

The service brake and the spring-loaded parking brake must be in the released state.

Use the adjuster to extend the tappet,
SB 3745 / SB 4309 / SB 4345 max. 30 mm,
SB 3308 max. 40 mm,
until the bellows seal is clearly visible.

The bellows on the tappets (arrow) must have no splits or damage.

Check for correct fitting.

Note: Penetrating dirt and moisture cause corrosion and affect the operation of the clamping mechanism and adjustment.

If water has penetrated or rusting has been detected, replace the brake caliper.

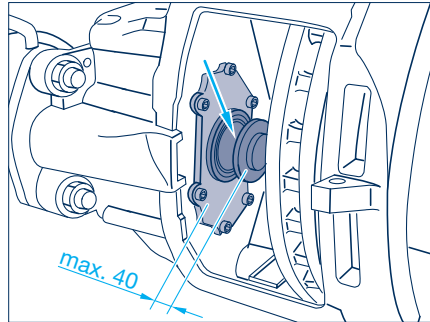
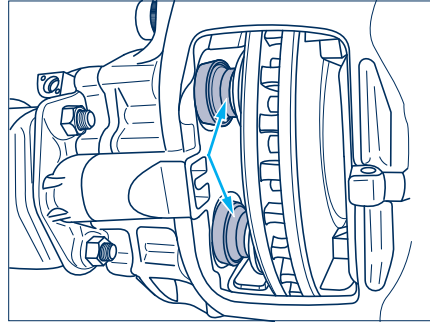

SB 3308

7 Check the caliper

- ECO Plus 2 and ECO^{Plus} axles, when used within Europe, at every brake pad change or every year at the latest; every six months outside Europe –
- ECO axles and axles with conventional mounting, every six months –

If damage to the parts becomes visible on the thrust tappet when the bellows are checked, both bellows must be dismantled. The parts which have been removed must be replaced by new ones.

Before the new parts are fitted, check that the adjusting unit is free of corrosion and operates smoothly.

To check the parts, turn the threaded tubes (1) (SB 3308 a threaded pipe) on the hexagon nut (size 8 or size 10 with an adapter) of the adjuster clockwise onto the brake disc (2).

The threads of the threaded tubes (1) can be checked during the turning process for corrosion damage.

If the threads are rusted, the brake caliper must be replaced.

Note:

To prevent the threaded tubes (1) from being turned completely out of the caliper, insert a new brake pad (3) into the caliper in the outboard brake pad position.

To prevent the threaded tubes from being wound completely out of the caliper when working on a work bench, insert a separator (4) (approx. 75 mm, in the case of SB 3308, approx. 60 mm) between the tubes and the caliper housing.

If the threaded tubes are wound completely out of the caliper, the brake caliper must be replaced.

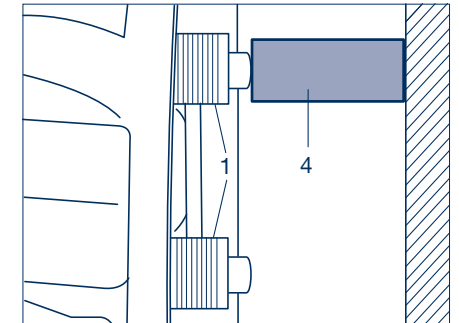
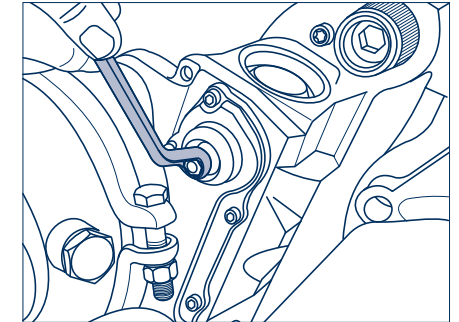
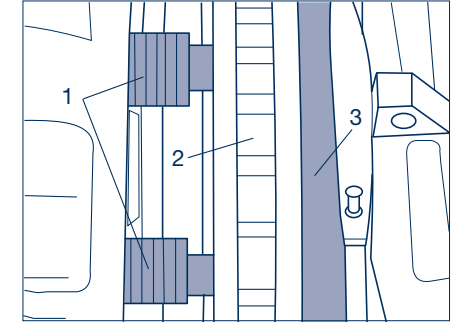

3 BPW Trailer axles / BPW Steering axles

3.2 Maintenance Work and Visual Inspection

3.2.4 Disc brakes, brake types: SB 3308, SB 3745, SB 4309, SB 4345

8 Check wheel hub bearing play

- ECO Plus 2 and ECO^{Plus} Unit at every brake pad change, however at least once a year –
- ECO Unit and conventional hub bearing every six months –

To check the wheel hub bearing play, raise the axle until the tyres are free. Release brake. Position lever between tyre and ground, and check play.

If you can feel play in the bearing, adjust the bearing play as described on pages 34 - 38.

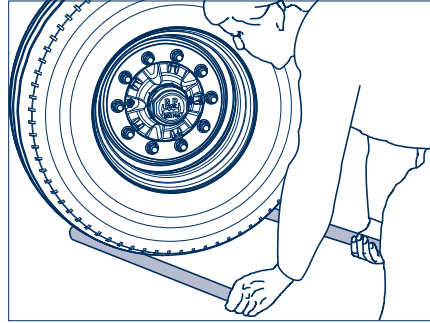

9 Check caps for tightness

- (not necessary with ECO Plus 2 and ECO^{Plus} axles)
- every 6 months and/ or as part of any other service inspection –

Check caps for tightness using a torque wrench or power tool.

Tightening torques:

Steel cap	5.5 t	M = 500 Nm
	6 - 12 t	M = 800 Nm
Alloy cap		M = 350 Nm

In an emergency the caps can be tightened using a normal cap spanner (vehicle tool kit) by striking the latter with a hammer, or also with the aid of a piece of tubing, inserted into the spanner.

Caps with integrated hubodometers must be fitted and dismantled using only torque controlled (do not use air impact wrenches) airguns or manually with a torque wrench.

Tighten to the correct tightening torque as soon as possible.

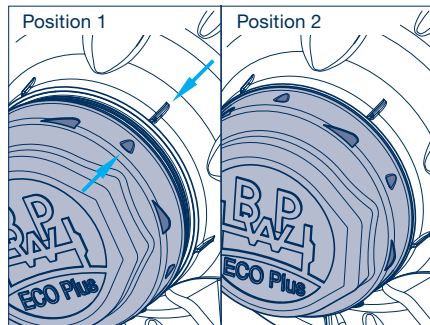
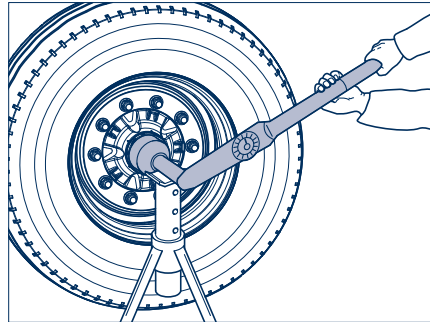

Note:

Caps on ECO Plus 2 axles are provided with a bayonet fitting. Check for firm seating.

Position 1: Hub cap seated loosely on the Unit.

Position 2: Hub cap seated firmly on the Unit.

4 BPW Air suspension, series EAC

4.1 Overview, Lubrication and Maintenance Work, Visual Inspection

Overview	Visual checks during the warranty period for chassis fitted with ECO Plus air suspension after 12, 36, 60 and 72 months, subsequently yearly
For detailed description, see pages 66 - 71 Air suspension series O, SL, AL see pages 72 - 84 Suspension, see pages 86 - 95	
1 Check air suspension levelling valve for condition, seal-tightness and general tightness.	1
2 Check condition of air bags.	2
- Visual inspection, check all component parts and welding seams for damage and wear.	-
3 Check shock absorber fastening for tightness. Tightening torque with a torque wrench: M 24 (SW 36) M = 420 Nm (390 - 460 Nm)	3
4 Check spring pivot bolts for tightness. Tightening torque with a torque wrench: M 24 (SW 36) M = 650 Nm (605 - 715 Nm)	4
5 Check axle clamping for tightness. Tightening torque with a torque wrench: M 20 (SW 30) M = 420 Nm	5
6 Check the spring bolt to gusset plate connecting bolt for tightness. Tightening torques with a torque wrench: M 18 x 1.5 (SW 27) M = 420 Nm (390 - 460 Nm)	6
7 Check air bag fastening for tightness. Tightening torques with a torque wrench: M 12 (SW 17) M = 66 Nm M 16 (SW 22) M = 230 - 300 Nm Centre screw M 16 (SW 22) M = 300 Nm	7
8 Check axle lift for tightness. Tightening torques with a torque wrench: Supporting arm M 20 (SW 30) M = 350 Nm (325 - 385 Nm) Diaphragm cylinder M 16 (SW 24) M = 190 Nm (180 - 210 Nm) Hexagon screw M 12 (SW 17) M = 75 Nm Lock nut M 10 (SW 16) M = 38 Nm Cylinder cap screw M 10 (SW 8) M = 50 Nm	8

Note:

Components that have damage due to improper mounting are to be exchanged after a review by a BPW Service Centre.

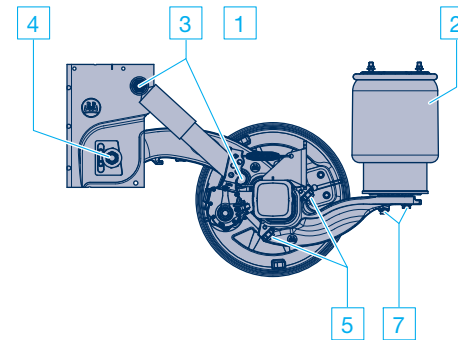

Serie ACBO

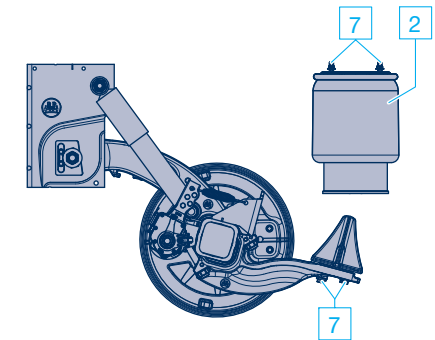

Serie ACBO with Kombi-Air Bag II

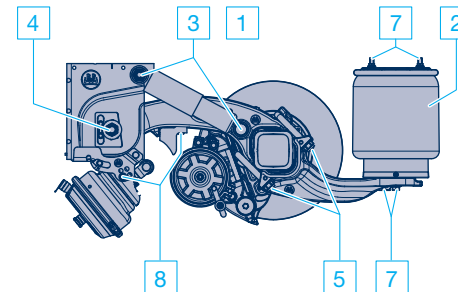

Series ACAM / ACBM
with two-sided axle lift

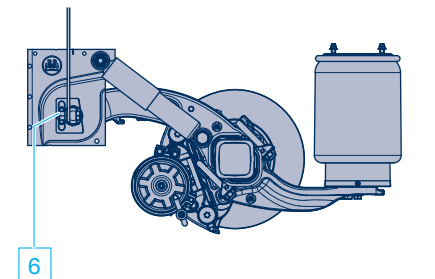

Serie ACBM with bolt-on gusset plate

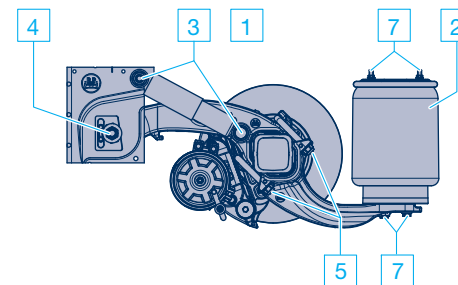

Series ACAU

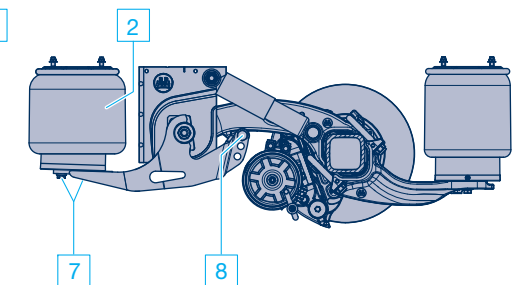

Serie ACAM with side mounted axle lift

4 BPW Air suspension, series EAC

4.2 Maintenance Work and Visual Inspection

1 Air installation circuit

– Service intervals as shown on page 64 –

Check air installation valves and line connections for firm seating, damage and seal tightness. Check valve linkage and fastenings (arrows) for damage and tightness.

The length of the valve lever and permissible angular positions for the valve linkage are shown in the illustration below.

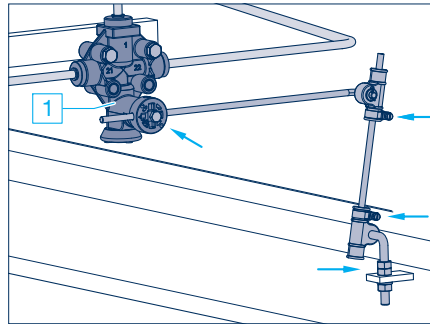

Air suspension valve

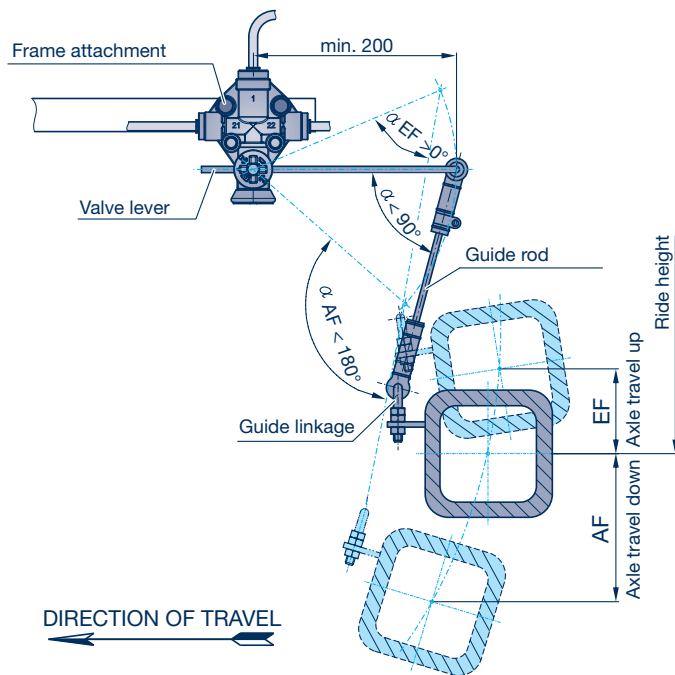

2 Air bags

– Service intervals as shown on page 64 –

Check air bags for external damage (surface cracking, abrasion, crease formation, trapped foreign bodies etc.). Replace air bags in the event of damage.

⚠ Safety notice

No welding should be carried out on steel parts of air bags and pressure vessel!

The air suspension should only be filled with compressed air when mounted. Danger of injury!

- Visual inspection

– Service intervals as shown on page 64 –

Check all component parts and welding seams for wear and damage.

3 Shock absorber fastening

– Service intervals as shown on page 64 –

Check lower and upper shock absorber fastening for tightness.

Check condition and wear of the rubber bush and replace where appropriate.

Check shock absorbers for oil leakage. In cases of distinct traces of oil, the shock absorber must be replaced. A light mist of oil is acceptable!

Tightening torques with a torque wrench:

M 24 (SW 36) M = **420 Nm** (390 - 460 Nm)

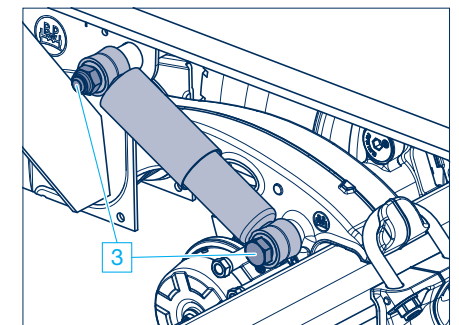
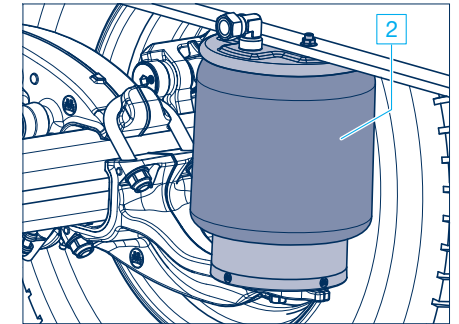

4 BPW Air suspension, series EAC

4.2 Maintenance Work and Visual Inspection

4 Spring pivot bolts

– Service intervals as shown on page 64 –

Check bushes; move vehicle back and forth slightly with brakes applied or move spring eyes with assembly lever with brakes released. No play should be present in the rolled spring end when doing so. If the fastening is loose the spring pivot bolt may be damaged.

- Check the lateral wear washers in the hanger bracket.
- Check the M 24 lock nut on the spring pivot bolt for tightness.

Tightening torque with a torque wrench:

M 24 (SW 36) M = **650 Nm** (605 - 715 Nm)

The life expectancy of the bearing depends on the tightness of the spring bolt or the inner bush.

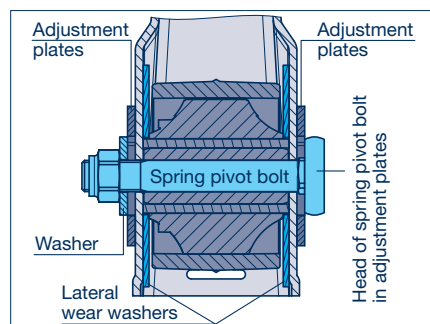
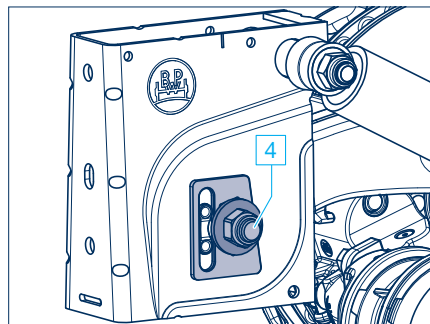

5 Axle clamping

– Service intervals as shown on page 64 –

Check lock nuts of spring U-bolts for tightness. If loose, tighten nuts alternately a little at a time.

Tightening torques with a torque wrench:

M 20 (SW 30) M = **420 Nm**

When mounting new spring mounting kit components, tighten the M 20 locknuts to a tightening torque of: M = **420 Nm** + 90° angle tightening.



Note: Do not weld on the trailing arms and the bellows support!

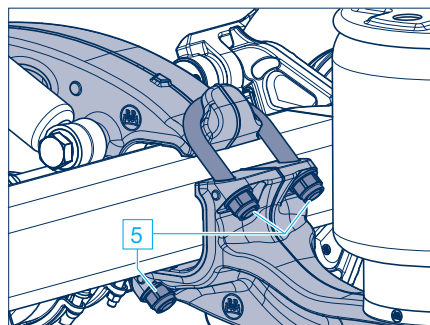

6 Bolted connection, gusset plate spring bolts

– Service intervals as shown on page 64 –

Check the mounting bolts of the gusset plates on the spring bolts are firmly tightened, and retighten with a torque wrench if necessary.

Tightening torque:

M 18 (SW 27) M = **420 Nm** (390 - 460 Nm)

Installing or renewing the spring bolt:

1. Unscrew or install the spring bolt.
2. Loosely pre-mount the gusset plate with at least three M 16 bolts at the top on the crossmember and one M 18 bolt at the bottom on the spring bolt and tighten further until contact is made.
3. Set the track.
4. Tighten the spring bolt to the prescribed tightening torque.
5. Tighten the connecting bolt on the gusset plates spring bolt and then tighten the upper connecting bolt to the prescribed tightening torques.

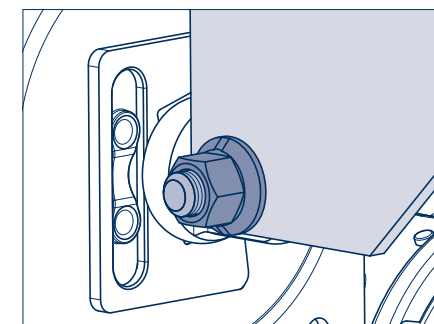
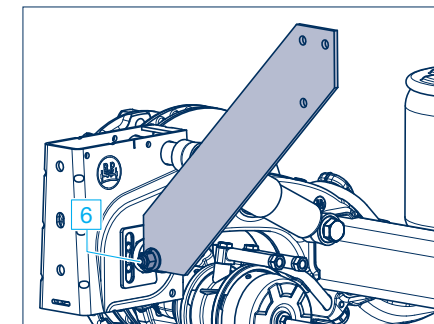

7 Air bag fastenings

– Service intervals as shown on page 64 –

Check air bag fixing bolts or nuts for tightness. If necessary, retighten.

Tightening torques with a torque wrench:

M 12 (SW 17) M = 66 Nm
M 16 (SW 22) M = 200 - 230 Nm

Lower attachment - centre screw:

M 16 (SW 22) M = 300 Nm

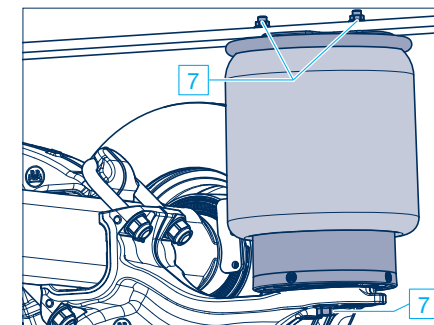

4 BPW Air suspension, series EAC

4.2 Maintenance Work and Visual Inspection

8 Axle lift

– Service intervals as shown on page 64 –

Sidewise mounted axle lift:

Check for tight fitting of the M 20 lock nut of the roller mounting on the lifting arm, if necessary tighten with a torque wrench.

Tightening torque:

M 20 (SW 30) M = **350 Nm** (325 - 385 Nm)

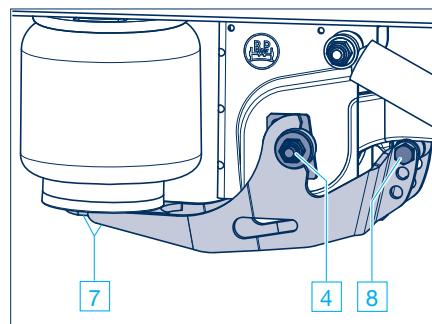

Two-sided lift:

a) Check the M 16 lock nuts on the diaphragm cylinder to make sure they are tight. Tighten with a torque wrench if necessary.

Tightening torque:

M 16 (SW 24) M = **190 Nm** (180 - 210 Nm)

b) Check for tight seating of the bump stop fixing screws on the trailing arms.

Tightening torque:

M 10 (SW 8) M = 50 Nm

c) Check for tight seating of the bracket fixing screws on the shaped plate.

Tightening torque:

M 12 (SW 17) M = 75 Nm

d) Check for the correct seating of the bolt circlip on the rear attachment support of the air suspension hanger brackets.

For versions from 2016, check for tight seating of lock nut.

M 10 (SW 16) M = 38 Nm

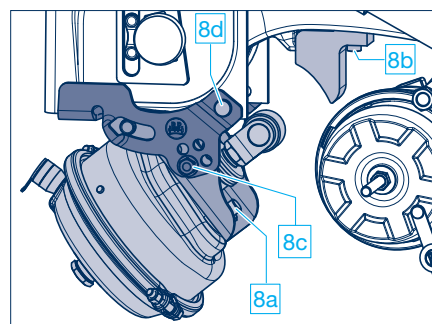

Spring pivot bolt bearing with axle lift

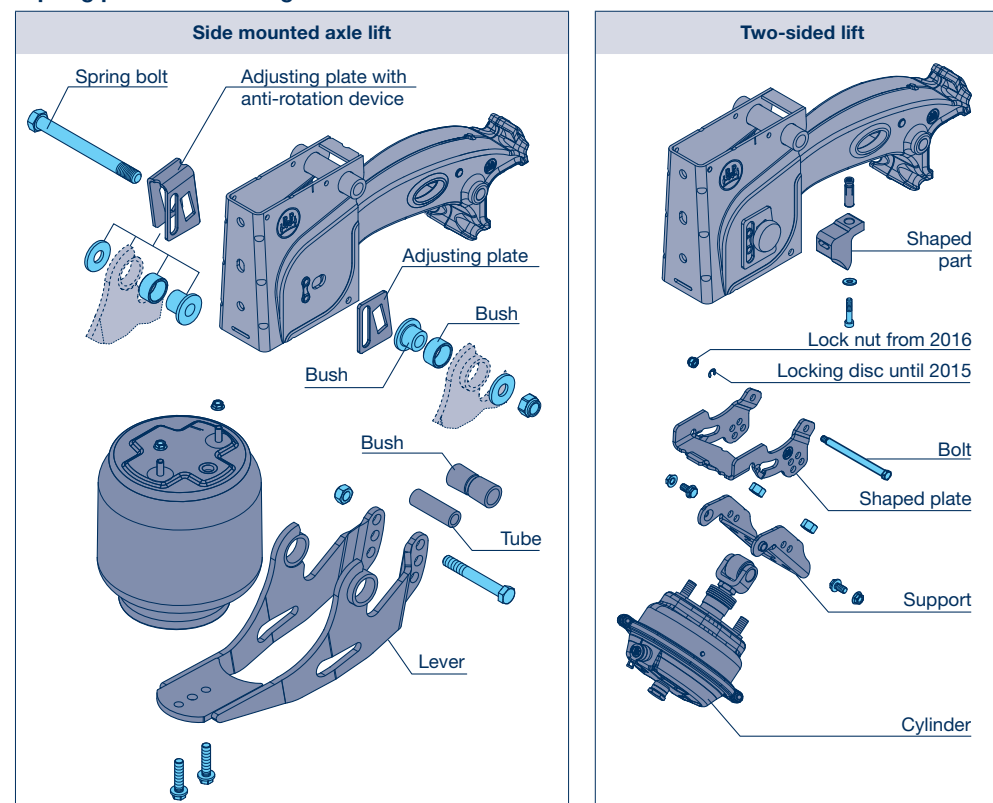

5 BPW Air suspension, series O, SL, AL

5.1 Overview, Lubrication and Maintenance Work, Visual Inspection

Overview	Within 2 weeks of first journey under load, latest after 2000 km ¹⁾	Visual checks during the warranty period for chassis fitted with ECO Plus air suspension after 12, 36, 60 and 72 months.	Annually ²⁾
For detailed description, see pages 76 - 84 Air suspension series EAC see pages 64 - 71 Suspension, see pages 86 - 95			
① Grease stabilizer bearing bushes with BPW special longlife grease ECO-Li ^{Plus} and check for wear.	①		① ³⁾
- Visual inspection, check all component parts and welding seams for damage and wear.		-	- ³⁾
① Check strap: Check condition and fastening.		①	①
② Check air suspension levelling valve for condition, seal-tightness and general tightness.		②	②
③ Check condition of air bags.		③	③
④ Check shock absorber fastening for tightness. Tightening torque with a torque wrench: M 20 (SW 30) M = 320 Nm (300 - 350 Nm) M 24 (SW 36) M = 420 Nm (390 - 460 Nm) For aluminium hanger brackets: M 24 (SW 36) M = 320 Nm (300 - 350 Nm)	④	④	④
⑤ Check spring pivot bolts for tightness. Tightening torque with a torque wrench: Hanger brackets and channel crossmember Airlight II from 09/2007: M 24 (SW 36) M = 650 Nm (605 - 715 Nm) Hanger brackets from 8/2001: M 30 (SW 46) M = 900 Nm (840 - 990 Nm) Hanger brackets up to 7/2001: M 30 (SW 46) M = 750 Nm (700 - 825 Nm) Channel crossmember: M 30 (SW 46) M = 900 Nm (840 - 990 Nm)	⑤	⑤	⑤
⑥ Check spring mounting kit for tightness. Tightening torque with a torque wrench: M 20 (SW 30) M = 340 Nm (315 - 375 Nm) M 22 (SW 32) M = 550 Nm (510 - 605 Nm) M 24 (SW 36) M = 650 Nm (605 - 715 Nm) When mounting new spring mounting kits for Airlight II: M 22 (SW 32) M = 550 Nm + 90° angle tightening	⑥	⑥	⑥

¹⁾ ECO Plus Units with Airlight II and Airlight Direct air suspension are maintenance-free in On-Road applications and do not need to be retightened (see warranty documents ECO Plus).

²⁾ Under extreme conditions, with more frequency.

³⁾ Check twice annually.

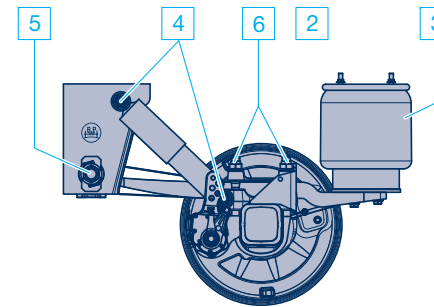

Series ALO/SLO

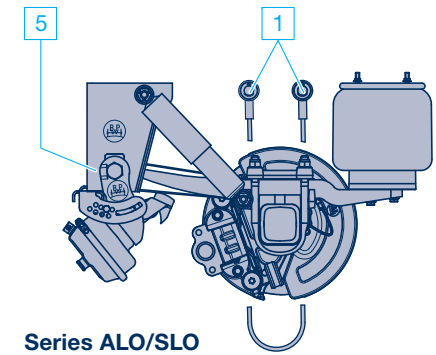

Series ALO/SLO
with two-sided axle lift

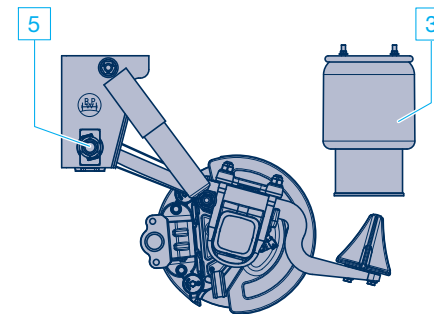

Series ALM/SLM with Kombi-Air Bag II

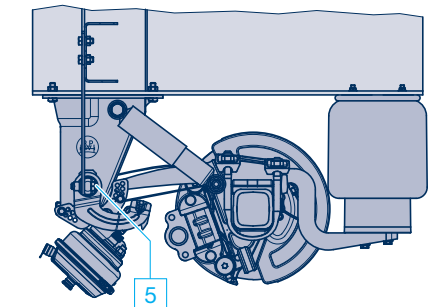

Series ALM/SLM with bolted-on
air suspension hanger bracket

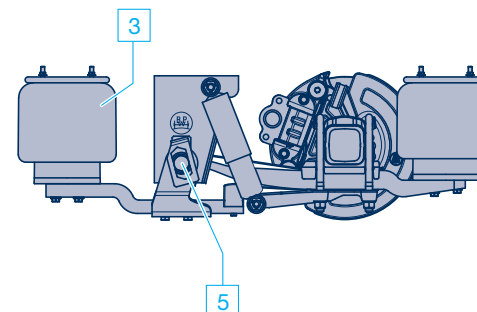

Series ALU/SLU with
sidewise mounted axle lift

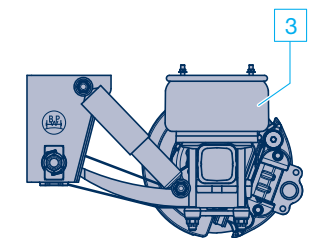

Series DLU - Airlight Direct

5 BPW Air suspension, series O, SL, AL

5.1 Overview, Lubrication and Maintenance Work, Visual Inspection

Overview		Within 2 weeks of first journey under load, latest after 2000 km ¹⁾	Visual checks during the warranty period for chassis fitted with ECO Plus air suspension after 12, 36, 60 and 72 months.	Annually ²⁾
For detailed description, see pages 76 - 84 Air suspension series EAC see pages 64 - 71 Suspension, see pages 86 - 95				
7	Check the bolt connection between the air suspension hanger bracket and the longitudinal member for tightness. Tightening torques with a torque wrench: M 16 M = 260 Nm (240 - 285 Nm)	7	7	7
8	Tighten the spring bolt to gusset plate connecting bolt. Tightening torques with a torque wrench: M 18 x 1.5 (SW 27) M = 420 Nm (390 - 460 Nm)	8	8	8
9	Check axle lift for tightness. Tightening torques with a torque wrench: Cylinder M 20 (SW 30) M = 350 - 380 Nm M 16 (SW 24) M = 180 - 210 Nm Supporting arm M 16 (SW 22) M = 230 Nm Hexagon screw M 12 (SW 17) M = 75 Nm	9	9	9
10	Check air bag fastening for tightness. Tightening torques with a torque wrench: M 12 (SW 17) M = 66 Nm M 16 (SW 22) M = 230 - 300 Nm Lower attachment - centre screw M 16 (SW 22) M = 300 Nm	10	10	10
11	Check stabilizer fastenings. Tightening torques with a torque wrench: M 10 (SW 17) M = 53 Nm M 30 (SW 46) M = 750 Nm (700 - 825 Nm)	11	11	11

¹⁾ ECO Plus Units with Airlight II and Airlight Direct air suspension are maintenance-free in On-Road applications and do not need to be retightened (see warranty documents ECO Plus).

²⁾ Under extreme conditions, with more frequency.

Note:

Components that have damage due to improper mounting are to be exchanged after a review by a BPW Service Centre.

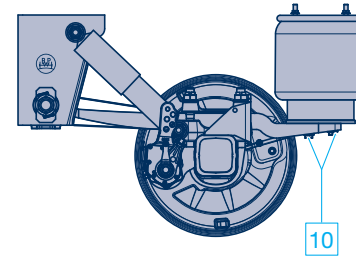

Series ALO/SLO

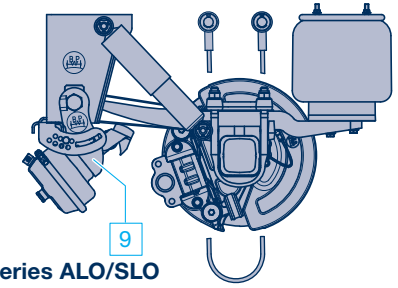

Series ALO/SLO
with two-sided axle lift

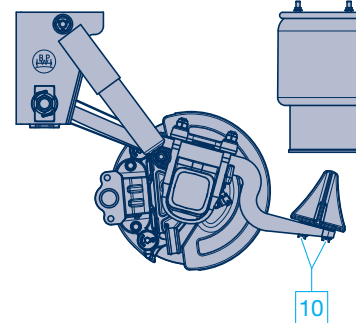

Series ALM/SLM
with Kombi-Air Bag II

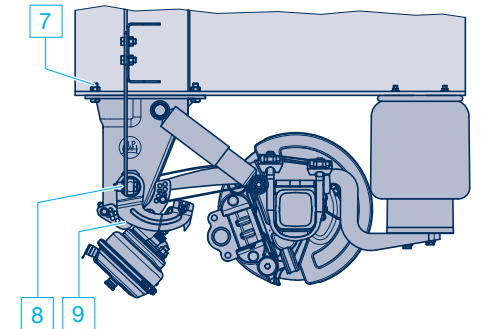

Series ALM/SLM with bolted-on air
suspension hanger bracket and bolt-on
double-sided lift

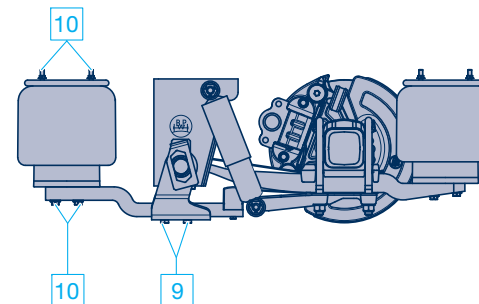

Series ALU/SLU
with sidewise mounted axle lift

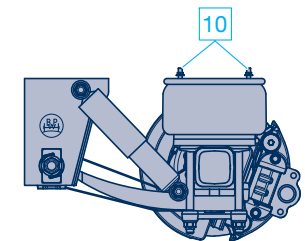

Series DLU - Airlight Direct

5 BPW Air suspension, series O, SL, AL

5.2 Lubrication

5.3 Maintenance Work and Visual Inspection

1 Stabilizer bearing bushes

– Service intervals as shown on page 72 –

Grease stabilizer bearing bushes with BPW special longlife grease ECO-Li^{Plus} and check for wear.

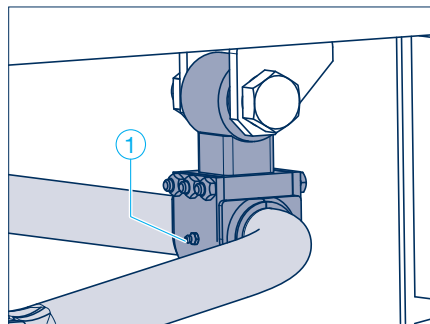

Visual inspection

– Service intervals as shown on page 72 –

Check all component parts and welding seams for wear and damage.

1 Check straps

– Service intervals as shown on page 72 –

Examine check straps and attachment. Replace if necessary.

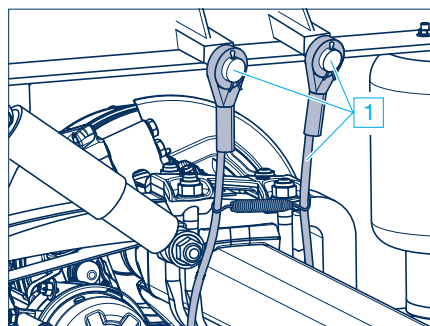

2 Air installation circuit

– Service intervals as shown on page 72 –

Check air installation valves and line connections for firm seating, damage and seal tightness. Check valve linkage and fastenings (arrows) for damage and tightness.

The length of the valve lever and permissible angular positions for the valve linkage are shown in the illustration below.

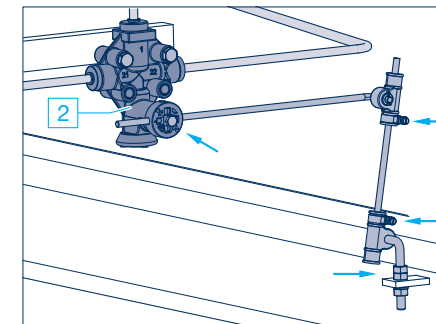

Air suspension valve

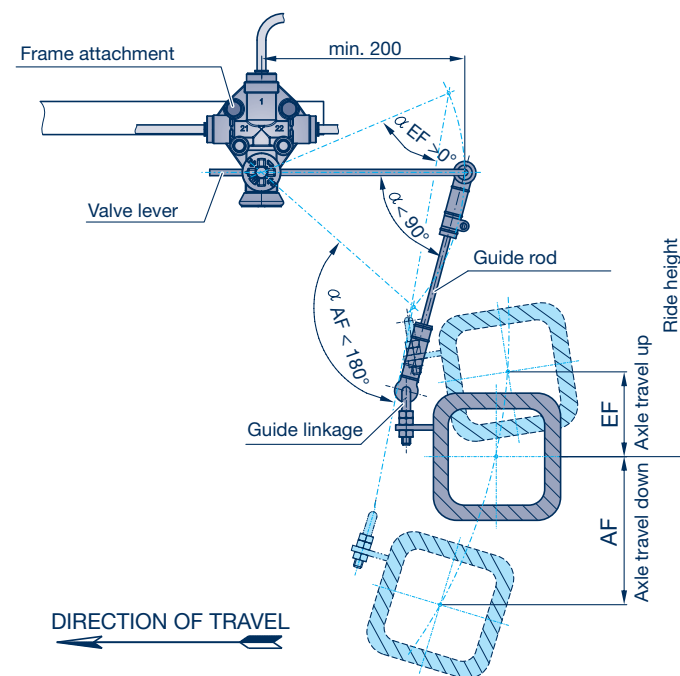

5 BPW Air suspension, series O, SL, AL

5.3 Maintenance Work and Visual Inspection

3 Air bags

– Service intervals as shown on page 72 –

Check air bags for external damage (surface cracking, abrasion, crease formation, trapped foreign bodies etc.). Replace air bags in the event of damage.

⚠ Safety notice

No welding should be carried out on steel parts of air bags and pressure vessel!

The air suspension should only be filled with compressed air when mounted.
Danger of injury!

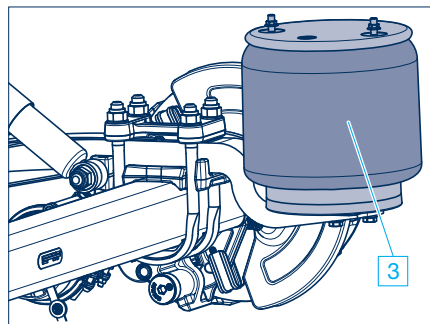

4 Shock absorber fastening

– Service intervals as shown on page 72 –

Check lower and upper shock absorber fastening for tightness. Tightening torques with a torque wrench.

Check condition and wear of the rubber bush and replace where appropriate.

Check shock absorbers for oil leakage. In cases of distinct traces of oil, the shock absorber must be replaced. A light mist of oil is acceptable!

Tightening torque:

M 20 (SW 30) M = **320 Nm** (300 - 350 Nm)

M 24 (SW 36) M = **420 Nm** (390 - 460 Nm)

In the case of alloy hanger brackets:

M 24 (SW 36) M = **320 Nm** (300 - 350 Nm)

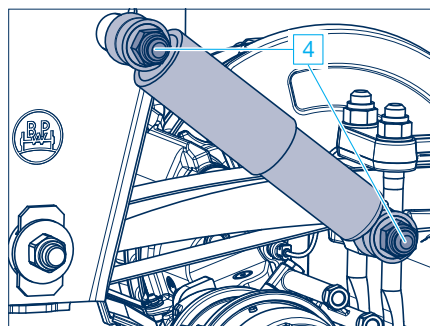

5 Spring pivot bolts

– Service intervals as shown on page 72 –

Check bushes, move vehicle back and forth slightly with the brake applied, or move rolled spring ends with the aid of a lever. No play should be present in the rolled spring end when doing so. If the fastening is loose the spring pivot bolt may be damaged.

- Check the lateral wear washers in the hanger bracket.
- Check the M 24 or M 30 lock nut on the spring pivot bolt for tightness.

Tightening torque with a torque wrench:

Air suspension hanger brackets and channel crossmember from 09/2007:
M 24 (SW 36) M = **650 Nm** (605 - 715 Nm)

Hanger brackets from 08/2001:
M 30 (SW 46) M = **900 Nm** (840 - 990 Nm)

Hanger brackets up to 07/2001:
M 30 (SW 46) M = **750 Nm** (700 - 825 Nm)

Channel crossmember:
M 30 (SW 46) M = **900 Nm** (840 - 990 Nm)

The serviceable life of the rubber / steel bush is dependent on the tightness of the inner steel bushing.

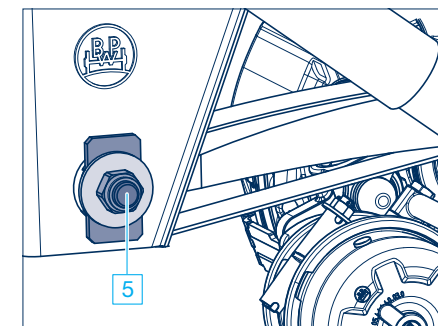

Non-adjustable hanger bracket

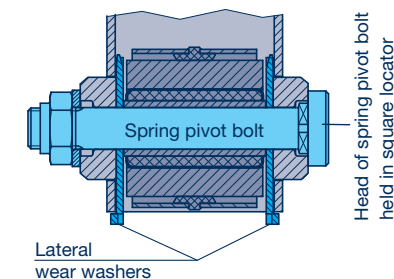

Adjustable hanger bracket

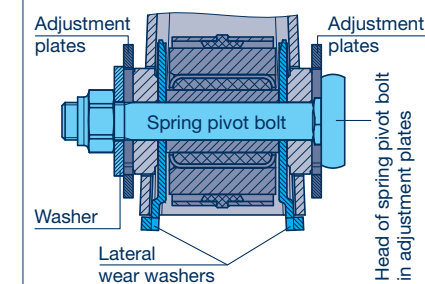

5 BPW Air suspension, series O, SL, AL

5.3 Maintenance Work and Visual Inspection

6 Spring mounting kit

– Service intervals as shown on page 72 –

Check lock nuts of spring U-bolts for tightness. If loose, tighten nuts alternately a little at a time.

Tightening torques with a torque wrench:

M 20 (SW 30)	M = 340 Nm (315 - 375 Nm)
M 22 (SW 32)	M = 550 Nm (510 - 605 Nm)
M 24 (SW 36)	M = 650 Nm (605 - 715 Nm)

When mounting new spring mounting kit components for Airlight II, tighten the M 22 locknuts to a tightening torque of:

M = 550 Nm + 90° angle tightening.

 **Note:** No welding should be performed on the trailing arm spring!

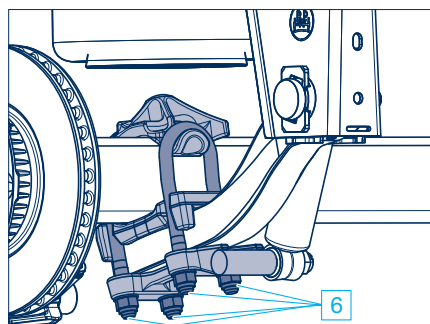
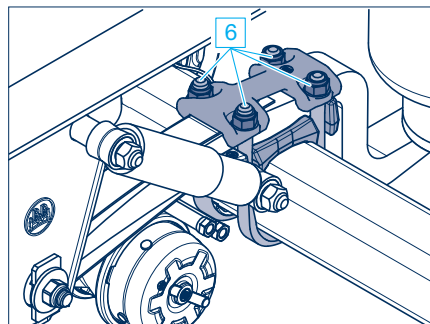

7 Bolted connection, air suspension hanger bracket to longitudinal chassis beam

– Service intervals as shown on page 74 –

Check that the mounting bolts of the air suspension hanger bracket on the longitudinal member are firmly tightened.

Tighten with a torque wrench if necessary.

Tightening torque:

M 16 M = **260 Nm** (240 - 285 Nm)

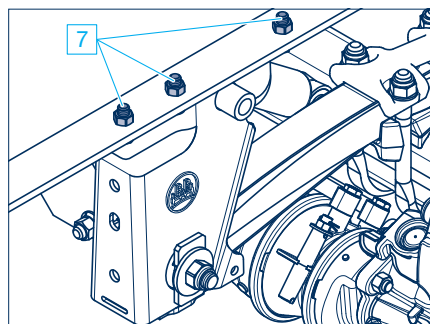

8 Bolted connection, gusset plate spring bolts

– Service intervals as shown on page 74 –

Check the mounting bolts of the gusset plates on the spring bolts are firmly tightened, and retighten with a torque wrench if necessary.

Tightening torque:

M 18 x 1.5 (SW 27) M = **420 Nm** (390 - 460 Nm)

Installing or renewing the spring bolt:

1. Unscrew or install the spring bolt.
2. Loosely pre-mount the gusset plate with at least three M 16 bolts at the top on the cross-member and one M 18 bolt at the bottom on the spring bolt and tighten further until contact is made.
3. Set the track.
4. Tighten the spring bolt to the prescribed tightening torque.
5. Tighten the connecting bolt on the gusset plates spring bolt and then tighten the upper connecting bolt to the prescribed tightening torques.

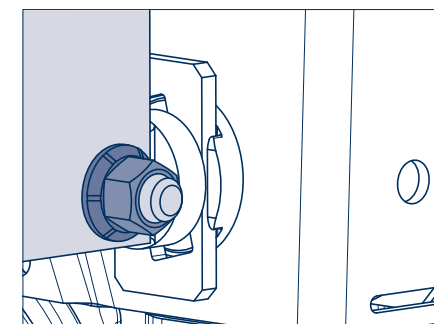
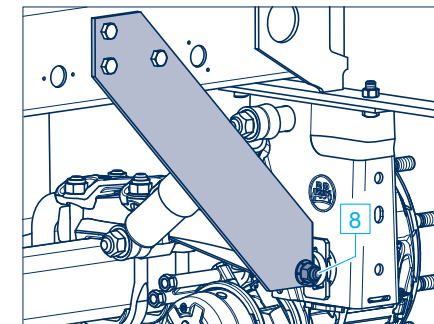

5 BPW Air suspension, series O, SL, AL

5.3 Maintenance Work and Visual Inspection

9 Axle lift

– Service intervals as shown on page 74 –

Single-sided lift

Check the M16 lock nuts on the lever arm fixing to make sure they are tight. Tighten with a torque wrench if necessary.

Tightening torque:

M 16 (SW 22) M = 230 Nm

Check for wear on the bump stop on the lever arm. Make sure it is secure.

Tightening torque:

M 10 (SW 17) M = 25 Nm
M 12 (SW 17) M = 66 Nm

Two-sided lift:

a) Check the M 16 lock nuts on the diaphragm cylinder to make sure they are tight. Tighten with a torque wrench if necessary.

Tightening torque:

M 20 (SW 30) M = 350 - 380 Nm
M 16 (SW 24) M = 180 - 210 Nm

b) Check the bump stop on the lever arm for wear, and that the M 6 attachment bolts are firmly tightened.

c) Check that the attachment bolts of the front bracing strut of the mount on the air suspension hanger bracket are tight, and in the case of the bolt-on two-sided lift, the bolted connection on the air suspension hanger bracket.

Tightening torque:

M 12 (SW 17) M = 75 Nm

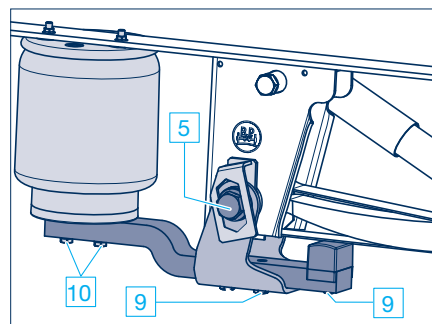

Single-sided lift

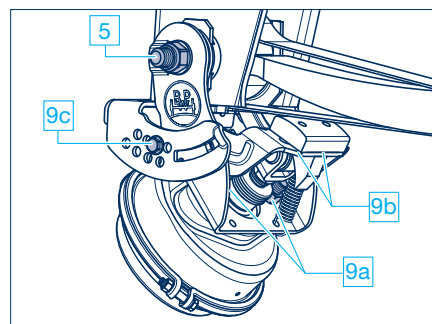

Two-sided lift

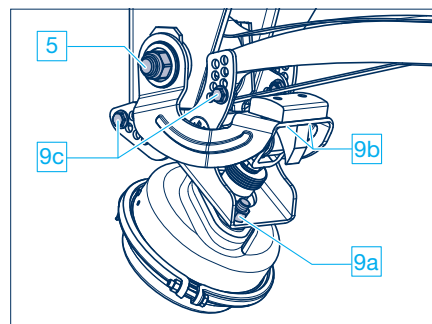

Bolt-on double-sided lift

Spring pivot bolt bearing with axle lift

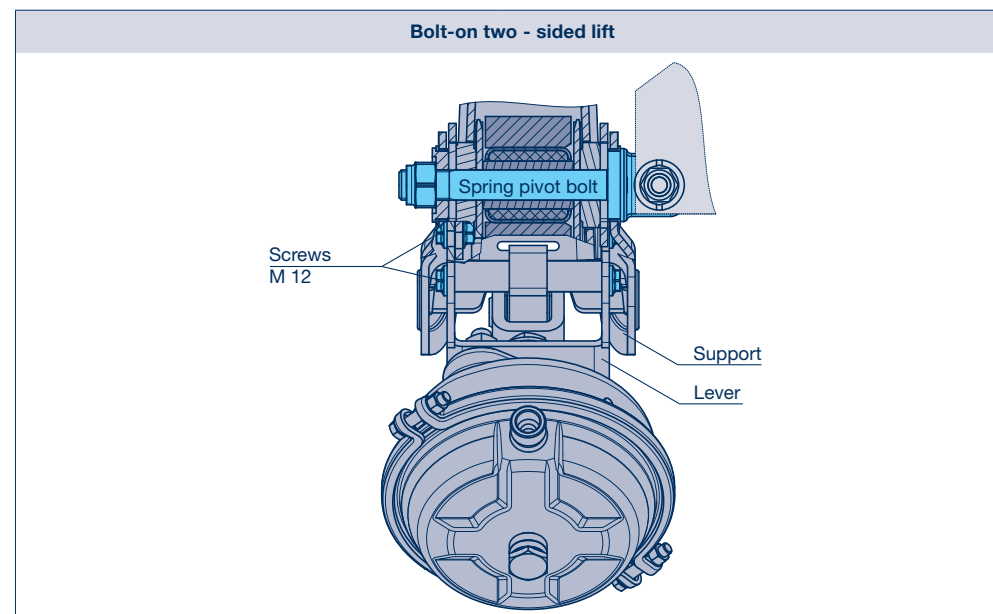
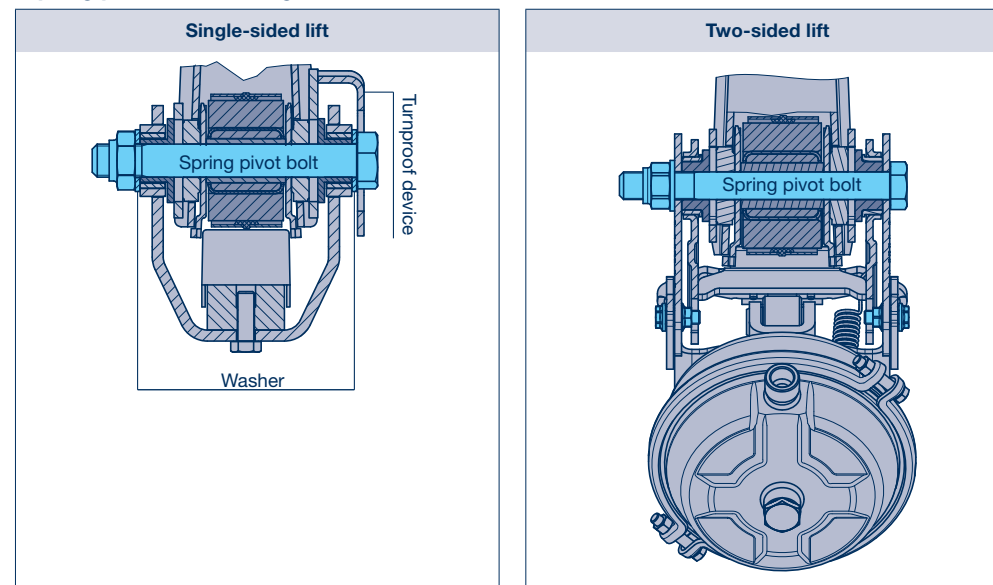

5 BPW Air suspension, series O, SL, AL

5.3 Maintenance Work and Visual Inspection

10 Air bag fastenings

– Service intervals as shown on page 74 –

Check air bag fixing bolts or nuts for tightness.
If necessary retighten using torque wrench.

Tightening torques with a torque wrench:

M 12 (SW 17)	M = 66 Nm
M 16 (SW 22)	M = 230 - 300 Nm

Lower attachment - centre screw

M 16 (SW 22)	M = 300 Nm
--------------	------------

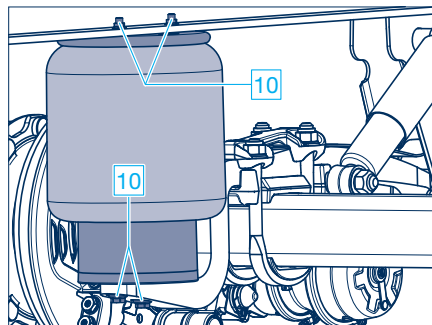

11 Stabilizer

– Service intervals as shown on page 74 –

Check stabilizer bearings for wear and tightness.

Tightening torques with a torque wrench:

M 10 (SW 17)	M = 53 Nm
M 30 (SW 46)	M = 750 Nm (700 - 825 Nm)

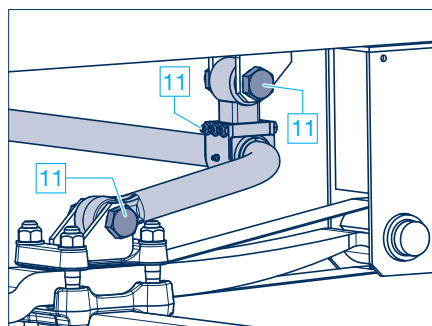

6 BPW Suspension, series ECO Cargo VB

6.1 Overview, Lubrication and Maintenance Work, Visual Inspection

Overview	Initially after 2 weeks	Every 6 weeks	Every 26 weeks (twice annually) ¹⁾
For detailed descriptions, see pages 88 - 91 For BPW trailer axles / steering axles, see pages 6 - 62			
① Grease bearings (suspension type E) with BPW special longlife grease ECO-Li ^{Plus} . (Not applicable in the case of rubber/steel bushes.)	<input type="radio"/>	<input type="radio"/>	
② Slightly grease the slide elements/slide ends of springs.	<input type="radio"/>	<input type="radio"/>	
① Check threaded bolts on equaliser arm bearings for tightness. up to an axle load of 5.5 tonnes (from 03/2016) M 30 (SW 46) M = 725 Nm up to an axle load of 12 tonnes (from 08/2013) M 42 x 3 (SW 65) M = 1300 Nm up to an axle load of 12 tonnes (up to 07/ 2013) M 42 x 3 (SW 65) M = 1100 Nm Series HD / HDE M 48 x 3 (SW 65) M = 1200 - 1300 Nm			<input type="checkbox"/>
② Check axle connecting rod bolts for tightness using a torque wrench. M 24 x 2 (SW 36) M = 650 Nm M 30 (SW 46) M = 725 Nm M 36 (SW 55) M = 1425 Nm	<input type="checkbox"/>		<input type="checkbox"/>
③ Check connecting rod clamping bolts for tightness. M 12 (SW 19) M = 66 Nm M 14 (SW 22) M = 140 Nm			<input type="checkbox"/>
④ Check spring U-bolts for tightness using a torque wrench. M 20 (SW 30) M = 315 - 375 Nm M 24 (SW 36) M = 600 - 650 Nm	<input type="checkbox"/>		<input type="checkbox"/>
- Visual inspection, check all component parts and welding seams for wear and damage.			<input type="checkbox"/>
⑤ Check spring pivot bolts for tightness. (Serie up to 5.5 t) M 20 (SW 30) M = 340 Nm	<input type="checkbox"/>		<input type="checkbox"/>
⑥ Check slide elements and rollers for tightness. M 14 (SW 22) M = 140 Nm M 16 (SW 24) M = 163 Nm M 20 (SW 30) M = 320 Nm			<input type="checkbox"/>

¹⁾ Under extreme conditions, with more frequency.

Note:

Components that have damage due to improper mounting are to be exchanged after a review by a BPW Service Centre.

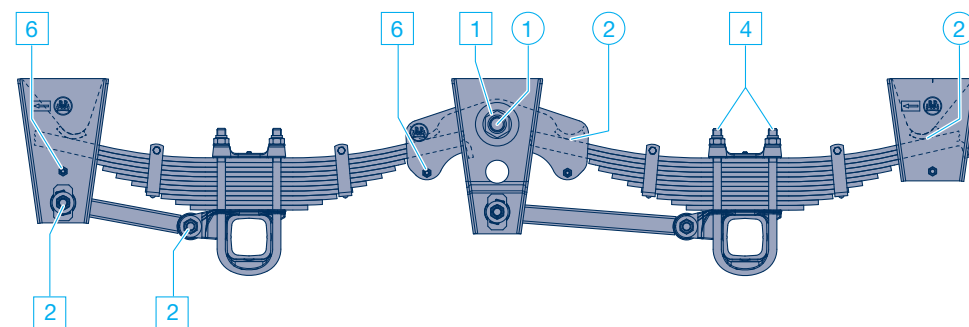

Series ECO Cargo VB ...M ...ME

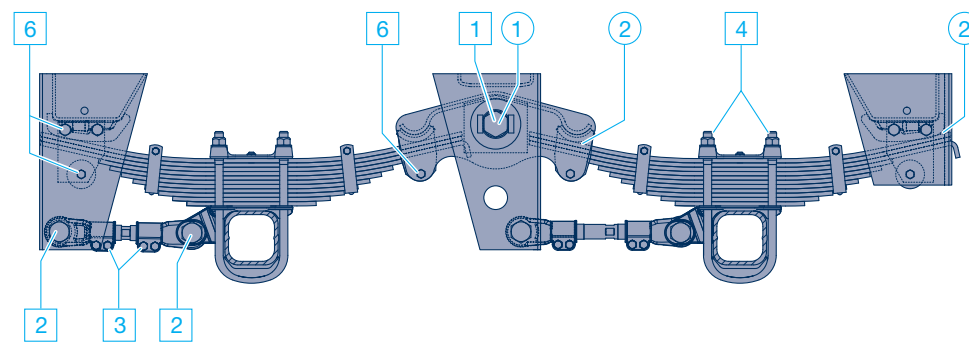

Series ECO Cargo VB HD / HDE

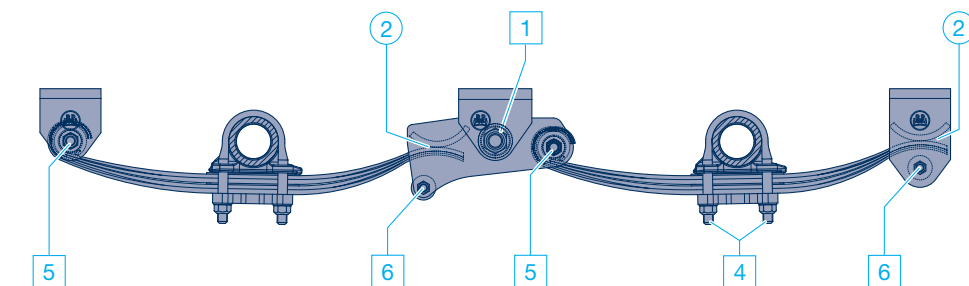

Series ECO Cargo VB 5,5 t

6 BPW Suspension, series ECO Cargo VB

6.2 Lubrication

- ① **Equalizer arm bearings** with bronze bushes (Series ECO Cargo VB ME and ECO Cargo VB HDE)
- initially after 2 weeks then every 6 weeks –
 - under extreme conditions, lubricate with more frequency –

Lift trailer to take pressure off equalizer arm bearings.

Grease bronze bush bearing via the grease nipple in the heads of the threaded bolts with BPW special longlife grease ECO-Li^{Plus} until fresh grease emerges. (Not applicable to rubber/steel bushes.)

At extremely low temperatures (-30° C to -50° C) a grease with correspondingly lower consistency class should be used - such as BPW ECO-Li Polar.

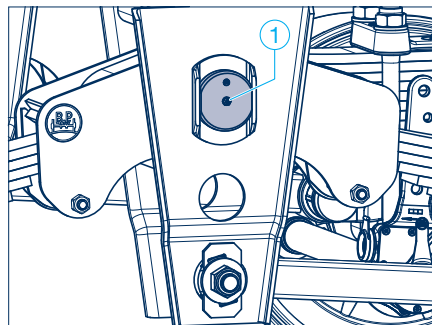

- ② **Slide elements**
- initially after 2 weeks then every 6 weeks –
 - under extreme conditions, lubricate with more frequency –

Clean and lightly grease the slides / slide ends of the springs.

In the case of ECO Cargo VB suspensions (up to 07/2013) with anti-vibration leaf underneath the parabolic springs, grease the lower slide elements via the grease nipples (arrow).

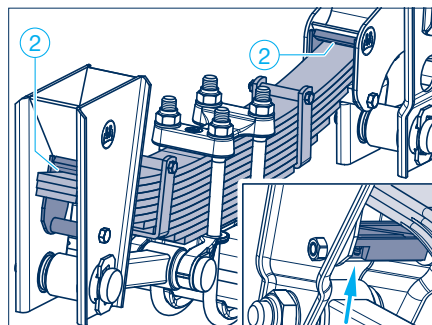

Maintenance Work and Visual Inspection 6.3

- ① **Equalizer arm bearings**
– twice annually –

Check nuts on the equalizer arm bearings for tightness. The serviceable life of the rubber/steel bush bearings is dependent on the tightness of the inner steel bush.

Tightening torques:

up to an axle load of 5.5 tonnes (from 03/2016)
M 30 (SW 46) M = 725 Nm

up to an axle load of 12 tonnes (from 08/2013)
M 42 x 3 (SW 65) M = 1300 Nm

up to an axle load of 12 tonnes (up to 07/2013)
M 42 x 3 (SW 65) M = 1100 Nm

Series HD / HDE

M 48 x 3 (SW 65) M = 1200 - 1300 Nm

- ② **Axle guide linkages**
– twice annually, initially after 2 weeks –

Check lock nuts of the axle guide linkages/connecting rods for tightness using a torque wrench.

Tightening torques:

M 24 x 2 (SW 36) M = 650 Nm

M 30 (SW 46) M = 725 Nm

M 36 (SW 65) M = 1425 Nm

- ③ **Connecting rods** (only at series VB up to manufacturing year 08.2013 and ECO Cargo VB HD)
– twice annually –

Check connecting rod clamping screws for tightness.

Tightening torques:

M 12 (SW 19) M = 66 Nm

M 14 (SW 22) M = 140 Nm

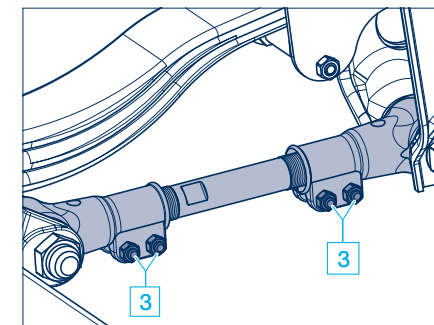
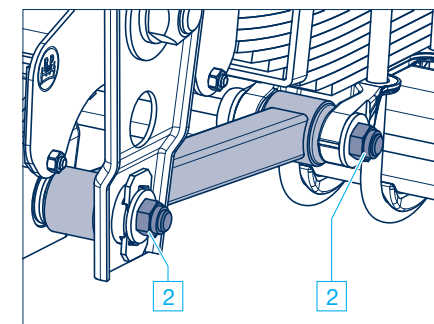
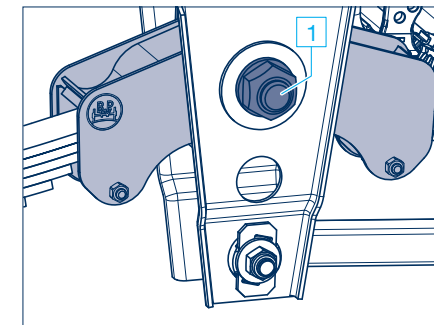

6 BPW Suspension, series ECO Cargo VB

6.3 Maintenance Work and Visual Inspection

4 Spring U-bolts

– initially after 2 weeks then twice annually –

Check spring U-bolts for tightness. If necessary loosen lock nuts, tighten nuts alternately to the prescribed torque, and a bit at a time, if necessary then re-lock.

Tightening torques:

M 20 (SW 30)	M = 315 - 375 Nm
M 24 (SW 36)	M = 600 - 650 Nm

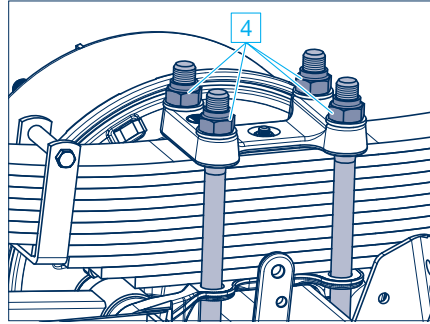

Visual inspection

– twice annually –

Check all component parts and welding seams for wear and damage.

In order to check the bearing on the equalizer and axle guide linkage, move the vehicle back and forth slightly with the brake applied; or move the bearing points with the aid of a lever. No play should be present in the bearing when doing so.

5 Spring pivot bolts (serie ECO Cargo VB up to 5.5 t)

– initially after 2 weeks then twice annually –

Check bushes; move vehicle back and forth slightly with brakes applied or move spring eyes with assembly lever with brakes released. No play should be present in the rolled spring end when doing so. If the fastening is loose the spring pivot bolt may be damaged.

Check the M 20 lock nut on the spring pivot bolt for tightness.

Tightening torque with a torque wrench:
M 20 (SW 30) M = 340 Nm

The life expectancy of the bearing depends on the tightness of the spring bolt or the inner bush.

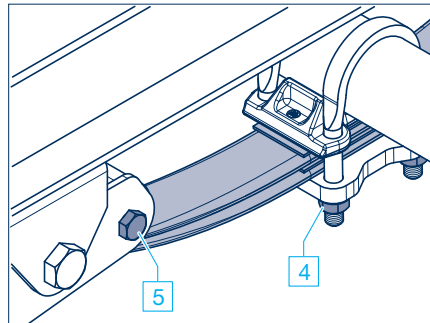

6 Slide elements

– twice annually –

Check slide elements and lateral wear plates in the shackle and equalizer arm for wear and the fastening screws for tightness.

Tightening torques:

M 14 (SW 22)	M = 140 Nm
M 16 (SW 24)	M = 163 Nm
M 20 (SW 30)	M = 320 Nm

If necessary, check rubber rollers under the spring ends for wear.

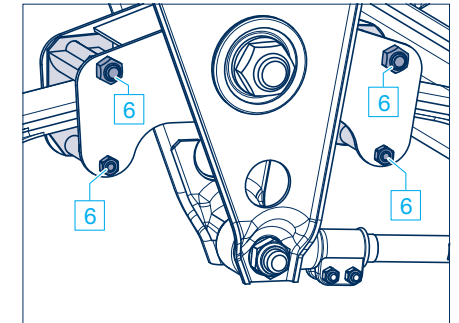
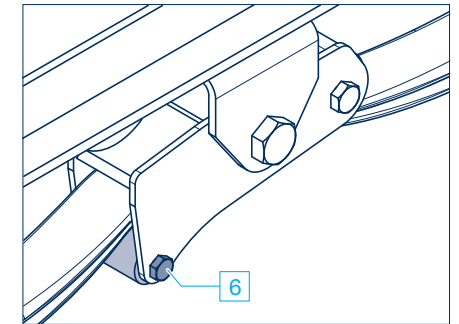
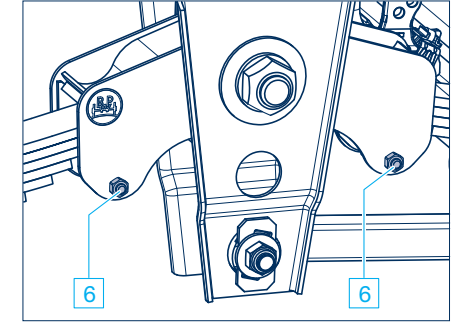

7 BPW Suspension, series ECO Cargo W / BW / GW

7.1 Overview, Lubrication and Maintenance Work, Visual Inspection

Overview	Initially after 2 weeks	Every 6 weeks	Every 26 weeks (twice annually) ¹⁾
For detailed description, see pages 94 - 95 BPW trailer axles / steering axles, see pages 6 - 62			
① Grease axle support bearing series W, BW using BPW special longlife grease ECO-Li ^{Plus} .	<input type="radio"/>	<input type="radio"/>	
② Grease spring housing series W using BPW special longlife grease ECO-Li ^{Plus} .	<input type="radio"/>	<input type="radio"/>	
- Visual inspection, check all component parts and welding seams for wear and damage.			<input type="checkbox"/>
① Check spring U-bolt of support axle for tightness. M 30 x 2 (SW 46) M = 980 Nm M 36 (SW 55) M = 1555 Nm	<input type="checkbox"/>		<input type="checkbox"/>
② Check fastening screws on the bearing covers for tightness. M 20 (SW 30) M = 320 Nm M 24 (SW 36) M = 570 Nm			<input type="checkbox"/>
③ Check spring U-bolts on the spring housing for tightness. M 20 (SW 30) M = 450 Nm M 24 (SW 36) M = 700 Nm	<input type="checkbox"/>		<input type="checkbox"/>

¹⁾ Under extreme conditions, with more frequency.

Note:

Components that have damage due to improper mounting are to be exchanged after a review by a BPW Service Centre.

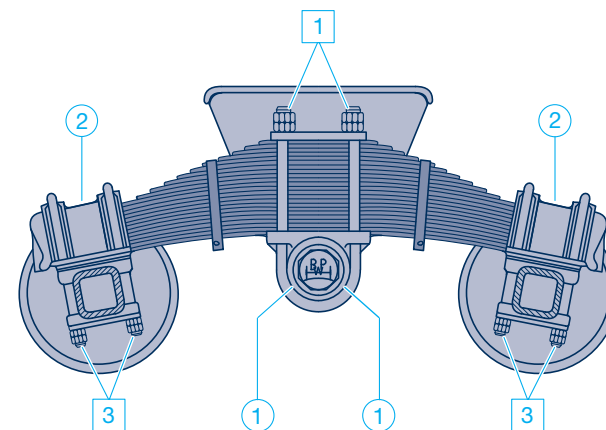

Series ECO Cargo W

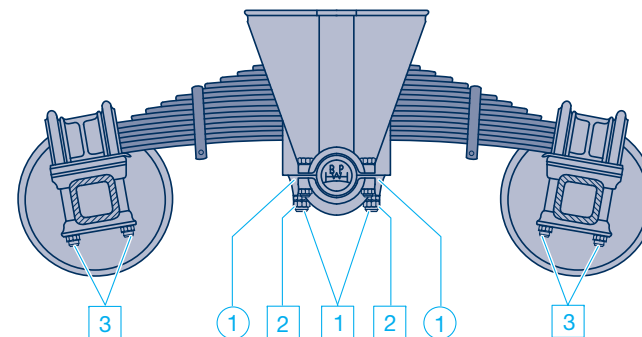

Series ECO Cargo BW / GW

7 BPW Suspension, series ECO Cargo W / BW / GW

7.2 Lubrication

① Support axle (series W, BW)

- initially after 2 weeks then every 6 weeks –
- under extreme conditions, lubricate with more frequency –

Lift trailer to take pressure off the trunnion bearings. Grease lubrication nipple front and rear on the bearing brackets of the support axle using BPW special longlife grease ECO-Li^{Plus} until fresh grease emerges (not applicable to axle assembly series GW = rubber bush).

At extremely low temperatures (-30° C up to 50° C) a grease with correspondingly lower consistency class should be used - such as BPW ECO-Li Polar.

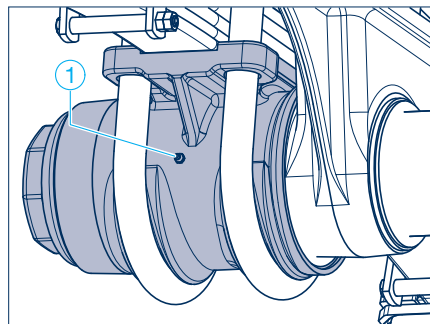

Series ECO Cargo W

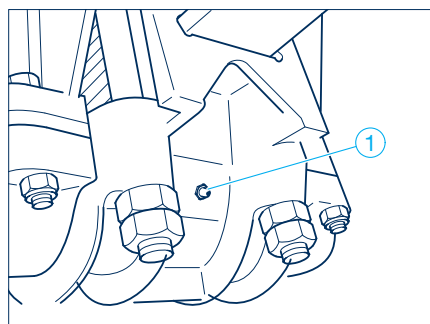

Series ECO Cargo BW

② Spring housing (series W)

- initially after 2 weeks then every 6 weeks –

Grease lubrication nipples on the spring housing using BPW special longlife grease ECO-Li^{Plus}.

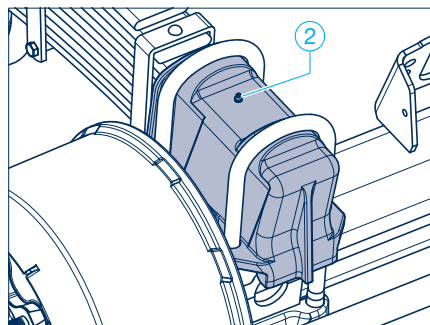

Series ECO Cargo W

Maintenance Work and Visual Inspection 7.3

- Visual inspection

- twice annually –

Check all components and welding seams for wear and damage.

① Spring U-bolts on the trunnion axle

- twice annually, initially after 2 weeks –

Check spring U-bolts for tightness. If necessary loosen lock nuts, tighten nuts alternately to the prescribed torque, a bit at a time, then relock.

Tightening torques:

M 30 x 2 (SW 46)	M = 980 Nm
M 36 (SW 55)	M = 1555 Nm

② Fastening screws on the cover plates

- twice annually –

Check the fastening screws on the cover plates of the support axle for tightness.

Tightening torques:

M 20 (SW 30)	M = 320 Nm
M 24 (SW 36)	M = 570 Nm

③ Spring U-bolts on the spring housings

- twice annually, initially after 2 weeks –

Check spring U-bolts on the spring housings for tightness. If necessary loosen lock nuts, tighten nuts alternately to the prescribed torque, a bit at a time, if necessary then relock.

Tightening torques:

M 20 (SW 30)	M = 450 Nm
M 24 (SW 36)	M = 700 Nm

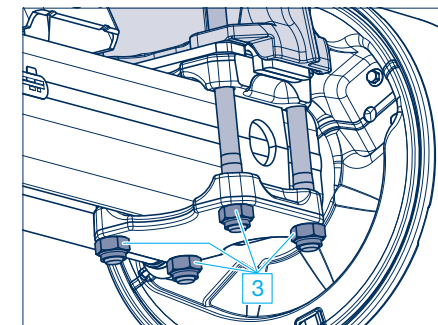
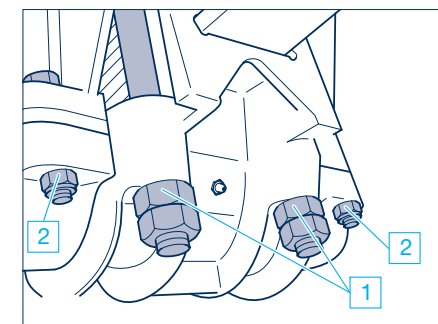
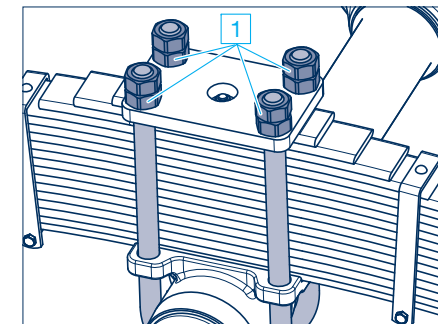



BPW-W 3311601e

BPW is a globally leading manufacturer of intelligent running gear systems for trailers and semi-trailers. As an international mobility and system partner, we offer a wide range of solutions for the transport industry from a single source, from axle to suspension and brake to user-friendly telematics applications.

We thereby ensure outstanding transparency in loading and transport processes and facilitate efficient fleet management. Today, the well-established brand represents an international corporation with a wide product and service portfolio for the commercial vehicle industry. Offering running gear systems, telematics, lighting systems, composite solutions and trailer superstructures, BPW is the right system partner for automotive manufacturers.

BPW, the owner-operated company, consistently pursues one target: To always give you exactly the solution which will pay off. To this end, we focus our attention on uncompromising quality for high reliability and service life, weight and time-saving concepts for low operating and maintenance costs as well as personal customer service and a close-knit service network for quick and direct support. You can be sure that with your international mobility partner BPW, you always use the most efficient method.

Your partner on the path to economic viability



BPW Bergische Achsen Kommanditgesellschaft

Postbox 12 80 · 51656 Wiehl, Germany · Phone +49 (0) 2262 78-0
info@bpw.de · www.bpw.de